

XI - 1

DRŽÁKY PROTLAČOVACÍCH NÁSTROJŮ



NTA s.r.o.
Komenského 365
763 16 Fryšták
www.nta.cz ntaoffice@nta.cz



XI

REV01-090129

DRŽÁK PROTlačOVACÍHO NÁSTROJE SEŘIZOVATELNÝ

Doporučení pro používání protlačovacího držáku

- OPRACOVÁVANÝ PRŮMĚR (OTVOR)

Jmenovitý rozměr (**P**) je rozměr protlačovacího trnu. Pokud je to možné zvolte otvor asi o 1% až 3% větší. Značně odlehčíte pohonu stroje a prodloužíte životnost nástroje.

- OTÁČKY

Doporučená hodnota: 1000 - 2000 (1/min)

- POSUV

Doporučená hodnota: 0,01 - 0,03 (mm/ot)

- CENROVÁNÍ PROTlačOVACÍHO ZAŘÍZENÍ

Pomocí seřizovacích šroubů (**Y**) zepředu a šroubů (**W**) shora, je možno osu nástroje (**K**) sesouhlasit s osou upínacího průměru (**d**), žádné další seřizování není potřebné.

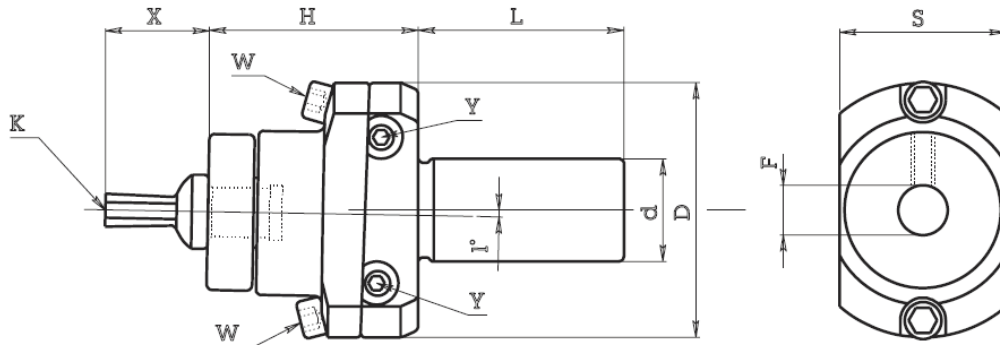

KOD	d	H	L	D	F	S
175.102	Morse 2	34	68	50	8	30
175.110	10	34	35	50	8	30
175.112	12	34	35	50	8	30
175.114	14	34	35	50	8	30
175.115	15,875	34	35	50	8	30
175.116	16	34	35	50	8	30
175.119	19,05	34	46	50	8	30
175.120	20	34	46	50	8	30
175.125	25	34	46	50	8	30
175.126	25,40	34	46	50	8	30

KOD	d	H	L	D	F	S
175.202	Morse 2	52	68	62	12	40,5
175.219	19,05	52	50	62	12	40,5
175.220	20	52	50	62	12	40,5
175.222	22	52	50	62	12	40,5
175.225	25	52	50	62	12	40,5
175.226	25,40	52	50	62	12	40,5
175.230	30	52	50	62	12	40,5
175.231	31,75	52	50	62	12	40,5
175.232	32	52	50	62	12	40,5

Na tento držák lze použít nástroje popsané na stranách 4-5

Příklady tvarů nástrojů

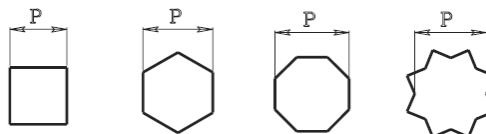

DRŽÁK PROTLAČOVACÍHO NÁSTROJE

KOD	d	I	L	D	F	H
175.508	8	34	35	22	5	10
175.510	10	34	35	22	5	10
175.512	12	34	35	22	5	10
175.514	14	34	35	22	5	10
175.515	15,875	34	35	22	5	10
175.516	16	34	35	22	5	10
175.519	19,05	34	46	22	5	10
175.520	20	34	46	22	5	10
175.522	22	34	46	22	5	10

KOD	d	I	L	D	F	H
175.602	Morse 2	38	69	32	8	18
175.610	10	38	35	32	8	18
175.612	12	38	35	32	8	18
175.614	14	38	35	32	8	18
175.615	15,875	38	35	32	8	18
175.616	16	38	35	32	8	18
175.619	19,05	38	50	32	8	18
175.620	20	38	50	32	8	18
175.622	22	38	50	32	8	18
175.625	25	38	50	32	8	18
175.626	25,40	38	50	32	8	18



KOD	d	I	L	D	F	H
175.702	Morse 2	46	69	44	12	25
175.716	16	46	50	44	12	25
175.719	19,05	46	50	44	12	25
175.720	20	46	50	44	12	25
175.722	22	46	50	44	12	25
175.725	25	46	50	44	12	25
175.726	25,40	46	50	44	12	25
175.732	32	46	50	44	12	25

Na tyto držáky lze použít nástroje popsané na stranách 4-5

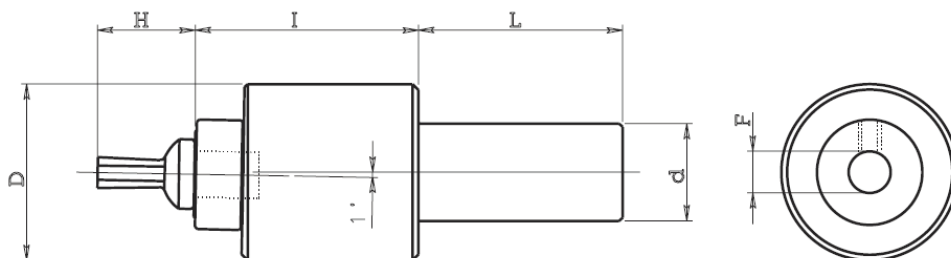

KOD	d	I	L	D	F	H
175.803	Morse 3	76	85	58	16	40
175.804	Morse 4	76	109	58	16	40
175.820	20	76	50	58	16	40
175.825	25	76	50	58	16	40
175.826	25,40	76	50	58	16	40
175.830	30	76	50	58	16	40
175.831	31,75	76	50	58	16	40
175.832	32	76	50	58	16	40
175.840	40	76	80	58	16	40

KLÍČ PRO DEMONTÁŽ LOŽISEK

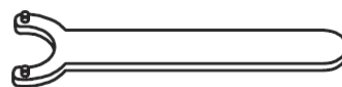

KOD	Pro držáky
175.500 H	175.500
175.600 H	175.600
175.700 H	175.700
175.800 H	175.800

PROTLAČOVACÍ NÁSTROJE

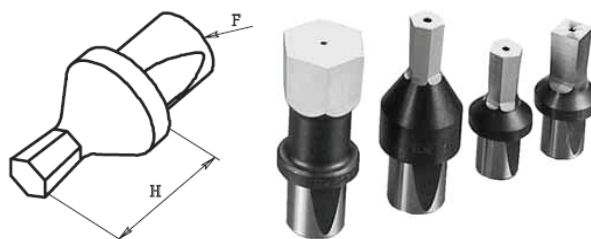

ŠESTIHRAN			
KOD	F	H	šestihran
803001	5	10	1
8030015	5	10	1,5
803002	5	10	2
8030025	5	10	2,5
803003	5	10	3
8030035	5	10	3,5
803004	5	10	4
803005	5	10	5
8030055	5	10	5,5
803006	5	10	6

ŠESTIHRAN			
KOD	F	H	šestihran
801001	8	18	1
8010015	8	18	1,5
801002	8	18	2
8010025	8	18	2,5
801003	8	18	3
8010035	8	18	3,5
801004	8	18	4
801005	8	18	5
8010055	8	18	5,5
801006	8	18	6
801007	8	18	7
801008	8	18	8

ŠESTIHRAN			
KOD	F	H	šestihran
800001	12	25	1
8000015	12	25	1,5
800002	12	25	2
8000025	12	25	2,5
800003	12	25	3
8000035	12	25	3,5
800004	12	25	4
800005	12	25	5
8000055	12	25	5,5
800006	12	25	6
800007	12	25	7
800008	12	25	8
800009	12	25	9
800010	12	25	10
800011	12	25	11
800012	12	25	12
800013	12	25	13
800014	12	25	14

ČTYŘHRAN			
KOD	F	H	čtyřhran
803101	5	10	1
8031015	5	10	1,5
803102	5	10	2
8031025	5	10	2,5
803103	5	10	3
8031035	5	10	3,5
803104	5	10	4
803105	5	10	5
8031055	5	10	5,5
803106	5	10	6

ČTYŘHRAN			
KOD	F	H	čtyřhran
801102	8	18	2
8011025	8	18	2,5
8011003	8	18	3
80110035	8	18	3,5
801104	8	18	4
801105	8	18	5
8011055	8	18	5,5
801106	8	18	6
801107	8	18	7

ČTYŘHRAN			
KOD	F	H	čtyřhran
800102	12	25	2
8001025	12	25	2,5
800103	12	25	3
8001035	12	25	3,5
800104	12	25	4
800105	12	25	5
8001055	12	25	5,5
800106	12	25	6
800107	12	25	7
800108	12	25	8
800109	12	25	9
800110	12	25	10
800111	12	25	11
800112	12	25	12
800113	12	25	13

PROTLAČOVACÍ NÁSTROJE

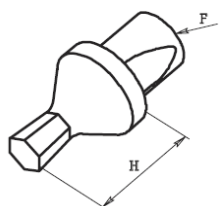

ŠESTIHRAN			
KOD	F	H	šestihran
802003	16	40	3
8020035	16	40	3,5
802004	16	40	4
802005	16	40	5
802006	16	40	6
802007	16	40	7
802008	16	40	8
802009	16	40	9
802010	16	40	10
802011	16	40	11
802012	16	40	12
802013	16	40	13
802014	16	40	14
802015	16	40	15
802016	16	40	16
802017	16	40	17
802018	16	40	18
802019	16	40	19
802020	16	40	20
802021	16	40	21
802022	16	40	22
802023	16	40	23
802024	16	40	24
802025	16	40	25

ČTYŘHRAN			
KOD	F	H	čtyřhran
802104	16	40	4
802105	16	40	5
802106	16	40	6
802107	16	40	7
802108	16	40	8
802109	16	40	9
802110	16	40	10
802111	16	40	11
802112	16	40	12
802113	16	40	13
802114	16	40	14
802115	16	40	15
802116	16	40	16
802117	16	40	17
802118	16	40	18
802119	16	40	19
802120	16	40	20
802121	16	40	21
802122	16	40	22
802123	16	40	23
802124	16	40	24
802125	16	40	25

PROTLAČOVACÍ NÁSTROJE EXTERNÍ

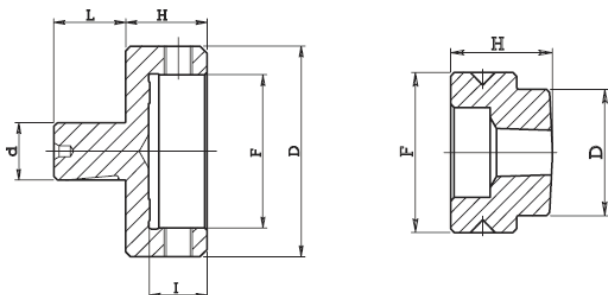

KOD	d	L	H	I	F	D
175790	12	15	17	12	32	44

Držák lze namontovat na zařízení kod:
175200, 175700 9R2.20.12, 9R2.30.12 a 9R2.40.12

KOD	d	L	H	I	F	D
175890	16	19	32	12	32	44

Držák lze namontovat na zařízení kod:
175800, 9R2.30.16 a 9R2.40.16

ŠESTIHRAN				
KOD	F	D	H	šestihran
Z 806003	32	25,3	20,5	3
Z 806004	32	25,3	20,5	4
Z 806005	32	25,3	20,5	5
Z 806006	32	25,3	20,5	6
Z 806007	32	25,3	20,5	7
Z 806008	32	25,3	20,5	8
Z 806009	32	25,3	20,5	9
Z 806010	32	25,3	20,5	10
Z 806011	32	25,3	20,5	11
Z 806012	32	25,3	20,5	12
Z 806013	32	25,3	20,5	13
Z 806014	32	25,3	20,5	14
Z 806015	32	25,3	20,5	15
Z 806016	32	30	20,5	16
Z 806017	32	30	20,5	17
Z 806018	32	30	20,5	18
Z 806019	32	30	20,5	19
Z 806020	32	30	20,5	20

ČTYŘHRAN				
KOD	F	D	H	čtyřhran
Z 806103	32	25,3	20,5	3
Z 806104	32	25,3	20,5	4
Z 806105	32	25,3	20,5	5
Z 806106	32	25,3	20,5	6
Z 806107	32	25,3	20,5	7
Z 806108	32	25,3	20,5	8
Z 806109	32	25,3	20,5	9
Z 806110	32	25,3	20,5	10
Z 806111	32	25,3	20,5	11
Z 806112	32	25,3	20,5	12
Z 806113	32	25,3	20,5	13
Z 806114	32	30	20,5	14
Z 806115	32	30	20,5	15
Z 806116	32	30	20,5	16
Z 806117	32	30	20,5	17
Z 806118	32	30	20,5	18

PROTLAČOVACÍ DRŽÁK VDI (DIN 69880)

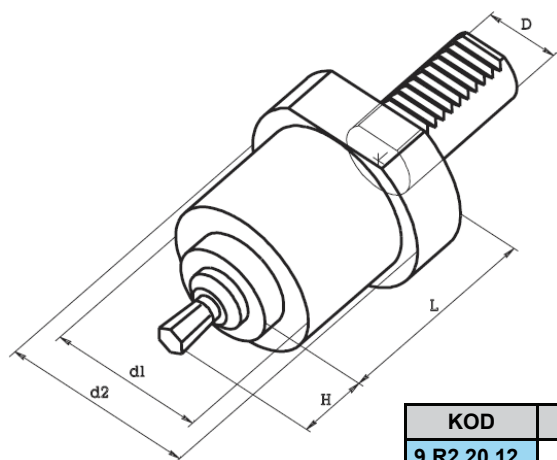

KOD	D	d1	d2	L	H	Otvor
9 R2.20.12	20	44	50	57	25	12
9 R2.30.12	30	58	68	83	25	12
9 R2.30.16	30	58	68	83	40	16
9 R2.40.12	40	58	83	83	25	12
9 R2.40.16	40	58	83	83	40	16

PROTLAČOVACÍ NÁSTROJE - TORX

KOD	F	H	P	S	R	torx*
801206	8	18	0,50-0,70	1,80	1,29	6
801208	8	18	0,70-0,90	2,45	1,80	8
801210	8	18	1,00-1,30	2,85	2,07	10
801215	8	18	1,30-1,50	3,38	2,44	15
801220	8	18	1,50-1,60	3,96	2,86	20
801225	8	18	1,60-2,00	4,55	3,28	25
801227	8	18	2,00-2,40	5,10	3,65	27
801230	8	18	2,60-3,00	5,65	4,07	30

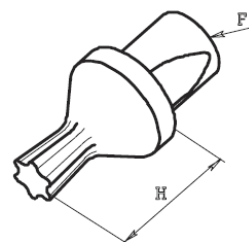

KOD	F	H	P	S	R	torx*
800206	12	25	0,50-0,70	1,80	1,29	6
800208	12	25	0,70-0,90	2,45	1,80	8
800210	12	25	1,00-1,30	2,85	2,07	10
800215	12	25	1,30-1,50	3,38	2,44	15
800220	12	25	1,50-1,60	3,96	2,86	20
800225	12	25	1,60-2,00	4,55	3,28	25
800227	12	25	2,00-2,40	5,10	3,65	27
800230	12	25	2,60-3,00	5,65	4,07	30
800240	12	25	3,00-3,30	6,80	4,88	40
800245	12	25	3,50-4,00	7,97	5,68	45
800250	12	25	4,00-4,50	8,99	6,50	50

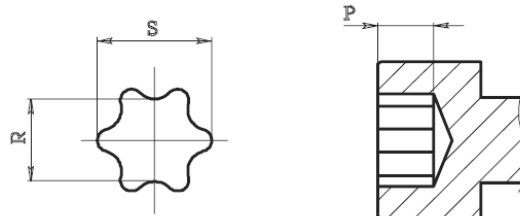

* Torx: registrovaná značka Textron inc. (USA) *