

IX- 1

# NÁHRADNÍ DÍLY PRO AUTOMATICKÉ SOUSTRUHY



NTA s.r.o.  
Komenského 365  
763 16 Fryšták  
[www.nta.cz](http://www.nta.cz) [ntaoffice@nta.cz](mailto:ntaoffice@nta.cz)



**IX**

REV02-130309

## POUZDRA A MATICE

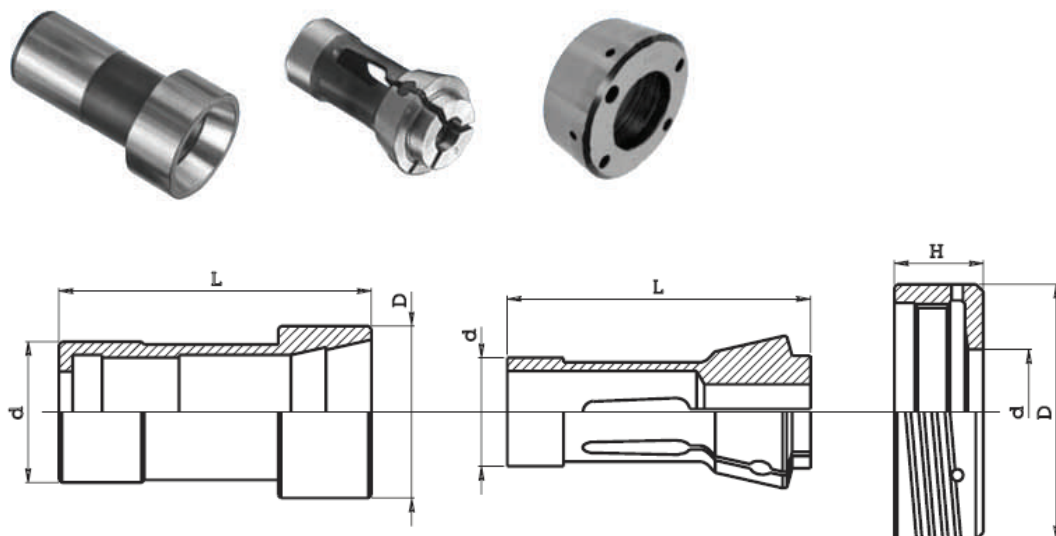

(B) = SG 30° - 3°  
(C) = utahovací otvory

POUZDRO				KLEŠTINA			MATICE					STROJ
KOD	d	D	L	KOD	d	L	KOD	D	d	H	Zavit vnitř.	
066.360	56	70	104	010.117	48	94	072.360	97	51	38.5	85x2 L (B)	INDEX 36 - B42
066.361	56	70	104	010.093	35	80	072.361	97	39	38.5	85x2 L (B)	INDEX 36 - B42 (reduk.)
066.360	56	70	104	010.117	48	94	072.363	102	51	30	85x2 L (B)	INDEX E42 - ER42
066.361	56	70	104	010.093	35	80	072.364	102	39	30	85x2 L (B)	INDEX E42 - ER42 (reduk.)
066.370	74	94	108	010.133	66	110	072.370	117	74.5	41.5	108x2 L (B)	INDEX 52
066.371	74	94	108	010.117	48	94	072.371	117	51	41.5	108x2 L (B)	INDEX 52 (reduk.)
066.380	74	94	120	010.133	66	110	072.380	122	74.5	34	108x2 L (B)	INDEX B60
066.381	74	94	120	010.117	48	94	072.381	122	51	34	108x2 L (B)	INDEX B60 (reduk.)
066.380	74	94	120	010.133	66	110	072.385	136	74.5	16	(C)	INDEX E60 - ER60
066.381	74	94	120	010.117	48	94	072.386	136	51	16	(C)	INDEX E60 - ER60 (reduk.)
066.240	37	50	92	010.084	32	75	072.420	74	35	39	61 x3	ITS TCA 301 (1)
066.240	37	50	92	010.084	32	75	072.420B	74	35	36	61 x3	ITS 26
066.430	58.8	70	140	010.117	48	94	072.430	108	52	34.5	92x2	ITS TCA 42
066.450	80	92	137	010.133	66	110	072.450	124	74.5	38	110x2	ITS 60
066.451	80	92	137	010.117	48	94	072.451	124	51	38	110x2	ITS 60 (reduk.)
066.520	58	63	116.5	010.117	48	94	072.520	92.5	51	22	75x2 L (B)	LOGOS LE 42
066.525	69	75	127	010.130	60	102	072.525	105.5	61	22	85x2 L (B)	LOGOG LE 52
066.910	28	40	70	010.051	22	55	—	—	—	—	—	MUPEN 15
066.572	21	25	55	010.030	15	47	—	—	—	—	—	PETERMAN P7R
066.572R	21	25	55	010.014	10	47	—	—	—	—	—	PETERMAN P7R (reduk.)
066.577	30	38	98	010.053	22	66	—	—	—	—	—	PETERMAN P16 - P16R
066.240	37	50	92	010.084	32	75	072.600	77	35	38	68x2	SAIC B26 (1)
066.610	42	55	96	010.093	35	80	072.610	79	39	39	66x3	SAIC B30
066.611	42	55	96	010.084	32	75	072.611	79	35	39	66x3	SAIC B30 (reduk.)
066.620	44	55	97	010.102	38	86	072.620	80	39	42	72x2	SAIC A30 - A32
066.621	44	55	97	010.084	32	75	072.621	80	35	42	72x2	SAIC A30 - A32 (reduk.)
066.640	58	70	130	010.117	48	94	072.640	103	51	50	88x4	SAIC B45
066.670	40	50	84	010.084	32	75	—	—	—	—	—	SKODA 20
066.791	12	15	66	010.006	8	42	—	—	—	—	—	STROHMM4-5
066.210	20	24	86	010.029	15	64	072.730	34	16	20	30x1.5 (B)	STROHM 105-125
066.735	35	40	100	010.064	25	77	072.741	63	28	40	56x1.5 (B)	STROHM 205
066.740	38	45	110	010.078	30	80	072.740	63	35	40	56x1.5 (B)	STROHM 255
066.741	38	45	110	010.064	25	77	072.741	63	28	40	56x1.5 (B)	STROHM 255 (reduk.)
066.756R	65	76	110	010.117	48	94	072.756R	115	51	42	100x2.5 L (B)	TAREX L52 (reduk.)

(1) Matice 072.420 lze namontovat na SAIC B 26 pokud je hřídel s válcovým vedením.

## Náhradní díly pro automatické soustruhy

## POUZDRA A MATICE

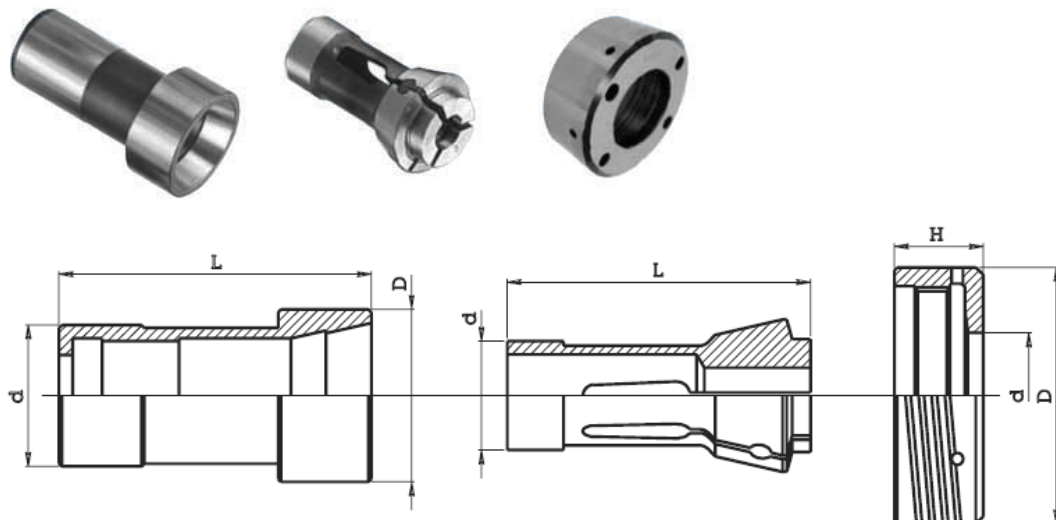

(B) = SG 30°- 3°  
(C) = utahovací otvory

POUZDRO			KLEŠTINA			MATICE					STROJ	
KOD	d	D	L	KOD	d	L	KOD	D	d	H		Závit vnitř.
066.788	42	44	105	010.074	30	65	—	—	—	—	—	TORNOS ENC 262-264
066.788B	38	44	110	010.074	30	65	—	—	—	—	—	TORNOS DECO 2000
066.788C	38	42	110	010.074	30	65	—	—	—	—	—	TORNOS DECO 2000
066.789	30	30	69	010.042	20	54	—	—	—	—	—	TORNOS ENC 164
066.790	15	15	51	010.006	8	42	—	—	—	—	—	TORNOS T4
066.791	12	15	66	010.006	8	42	—	—	—	—	—	TORNOS M4
066.794	22	26	90	010.029	15	64	072.794	37	16.5	17	33x1.25 L	TORNOS R10
066.800	28	38	70	010.051	22	55	—	—	—	—	52x3	TRAUB TC15
066.810	33	33	52	010.051	22	55	072.810	53	22	45	43.5x2	TRAUB A 15
066.820	34	42	67	010.070	28	70	072.820	63	29	39	52x3	TRAUB A 20
066.821	34	42	67	010.051	22	55	072.821	63	22	39	52x3	TRAUB A 20 (reduk.)
066.830	37	52	96	010.084	32	75	072.830	72	35	39	62x2.5	TRAUB A 25
066.831	37	52	96	010.051	22	55	072.831	72	22	39	62x2.5	TRAUB A 25 (reduk.)
066.850	40	52	96	010.084	32	75	072.830	72	35	39	62x2.5	TRAUB A 26
066.860	52	63	116	010.111	42	94	—	—	—	—	—	TRAUB A 36
066.870	54	68(75)	114	010.117	48	94	072.870	91	51	46	80x3	TRAUB A 42
066.871	54	68(75)	114	010.084	32	75	072.871	91	35	46	80x3	TRAUB A 42 (reduk.)
066.872	60	70	135	010.117	48	94	072.872	130	51	23	(C)	TRAUB TNS 42
066.872R	60	70	135	010.121	52	92	072.872R	130	55	23	(C)	TRAUB TNS 42
066.873	54	74	115	010.117	48	94	—	—	—	—	—	TRAUB TG 42/110
066.880	74	86(93)	114	010.133	66	110	072.880	105	74.5	44.5	98x3	TRAUB A 60
066.881	74	86(93)	114	010.117	48	94	072.881	105	51	44.5	98x3	TRAUB A 60 (reduk.)
066.885	75	95	138	010.133	66	110	072.885	140	74.5	22	(C)	TRAUB TNF 60/140
066.908	30	35	85	010.063	25	65	—	—	—	—	—	TRAUB TNL 16
066.910	28	40	70	010.051	22	55	—	—	—	—	—	TRAUB TD 16
066.920	40	54	95	010.084	32	75	072.920	78	35	40	70x3	TRAUB TD 26 (2)
066.920	40	54	95	010.084	32	75	072.920B	78	35	40	70x3	TRAUB TD 26 (3)
066.930	50	68	115	010.111	42	94	072.930	86	43.5	40	80x3	TRAUB TD 36 (2)
066.930	50	68	115	010.111	42	94	072.930B	86	43.5	40	80x3	TRAUB TD 36 (3)
066.931	50	68	115	010.084	32	75	072.931	86	35	40	80x3	TRAUB TD 36 (reduk.) (2)
066.931	50	68	115	010.084	32	75	072.931 B	86	35	40	80x3	TRAUB TD 36 (reduk.) (3)
066.870	54	68(75)	114	010.117	48	94	072.870	91	51	46	80x3	TRAUB TB 42
066.871	54	68(75)	114	010.084	32	94	072.871	91	35	46	80x3	TRAUB TB 42 (reduk.)
066.950	74	86(93)	138	010.133	66	110	072.880	105	74.5	44.5	98x3	TRAUB TB 60
066.951	74	86(93)	138	010.117	48	94	072.881	105	51	44.5	98x3	TRAUB TB 60 (reduk.)
066.952	82	95	138	010.133	66	110	—	—	—	—	—	TRAUB TF 60

(2) Stroje vyrobené do r. 1976

(3) Stroje vyrobené po r. 1976

## Náhradní díly pro automatické soustruhy

## POUZDRA A MATICE

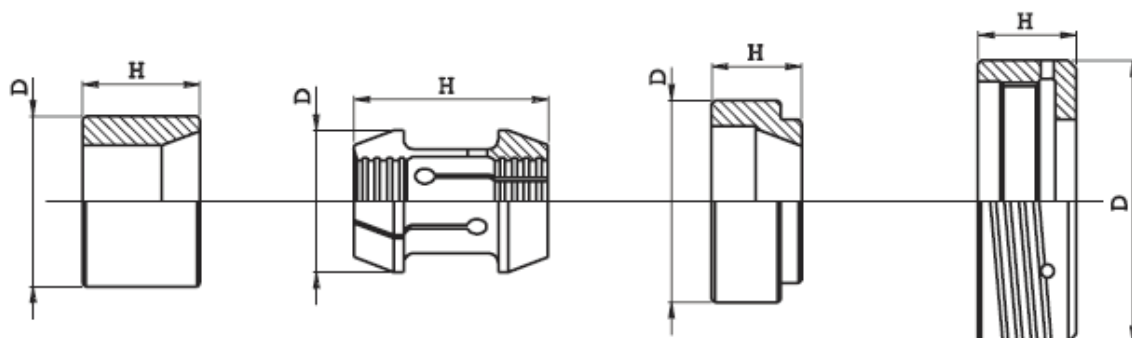

POUZDRO PŘEDNÍ			POUZDRO ZADNÍ			MATICE				KLEŠTINA			STROJ
KOD	D	H	KOD	D	H	KOD	D	H	Zavit vnitř.	KOD	D	H	
—	—	—	068.044	104	62	074.044	152	54	128x1.5	016.070	90	100	BIGLIA 110-131
—	—	—	068.044R	104	62	074.044R	152	54	128x1.5	016.043	60	80	BIGLIA 110-131
—	—	—	068.045	104	62	074.045	152	54	128x1.5	016.056	69.5	100	BIGLIA 110-131
—	—	—	068.045R	104	62	074.045R	152	54	128x1.5	016.057	71.6	100	BIGLIA 110-131
068.130A	48	27	068.130P	38	43	074.130	73.5	40	61x3	016.024	34	56	CASER TA 26
068.130AB	52	27	068.130P	38	43	074.130	73.5	40	61x3	016.024	34	56	CASER TA 26
068.132A	48	27	068.132P	38	24	074.130	73.5	40	61x3	016.052	34.5	74	CASER TA 26
068.132AB	52	27	068.132P	38	24	074.130	73.5	40	61x3	016.052	34.5	74	CASER TA 26
068.141A	52	40	068.141 P	42	36	074.140	75	39	64x3	016.052	34.5	74	CASER TA 30
068.160A	84	36	068.160P	60	103	074.160	108	53	98x3	016.051	70	80	CASER TA 50
068.161A	84	36	068.161 P	60	103	074.160	108	53	98x3	016.043	60	80	CASER TA 50 reduk.
068.240A	50	37	068.240P	37	55	074.240	79	42	70x3 L	016.024	34	56	GIORGI GM 25
068.242A	50	37	068.242P	37	38	074.240	79	42	70x3 L	016.052	34.5	74	GIORGI GM 25
068.250A	56	36	068.250P	44	43	072.250	79	42	70x3 L	016.053	43	84	GIORGI GM 32
068.251A	56	42	068.251P	44	39	072.250	79	42	70x3 L	016.052	34.5	74	GIORGI GM 32 reduk.
068.252A	56	42	068.252P	44	56	072.250	79	42	70x3 L	016.024	34	56	GIORGI GM 32 reduk.
068.240A	50	37	068.240P	37	55	074.420 (1)	74	39	61x3	016.024	34	56	ITS 26 (1)
068.242A	50	37	068.242P	37	38	074.420 (1)	74	39	61x3	016.052	34.5	74	ITS 26 (1)
068.240A	50	37	068.240P	37	55	074.600	77	38	68x3	016.024	34	56	SAIC B 26 (1)
068.242A	50	37	068.242P	37	38	074.600	77	38	68x3	016.052	34.5	74	SAIC B 26 (1)
068.610A	55	37	068.610P	42	39	074.610	79	39	66x3	016.033	40.5	75	SAIC B 30
068.611A	55	37	068.611P	42	39	074.610	79	39	66x3	016.052	34.5	74	SAIC B 30 reduk.
068.610A	55	37	068.610P	42	39	074.620	80	39.5	72x2	016.033	40.5	75	SAIC A 30-32
068.611A	55	37	068.611 P	42	39	074.620	80	39.5	72x2	016.052	34.5	74	SAIC A 30-32 reduk.
068.640A	70	30	068.640P	58(68)	84	074.640	103	50	88x4	016.043	60	80	SAIC B 45
- (2) -	—	—	068.810P	33	15	074.810	52	45	43.5x2	016.054	26	55	TRAUB A 15
068.821A	42	28	068.821 P	34	32	072.820	63	39	52x3	016.054	26	55	TRAUB A 20
068.830A	52	37	068.830P	37	59	074.830	72	39	62x2.5	016.024	34	56	TRAUB A 25
068.832A	52	37	068.832P	37	42	074.830	72	39	62x2.5	016.052	34.5	74	TRAUB A 25
068.870A	68	38	068.870P	54	58	074.870	91	46	80x3	016.055	50	80	TRAUB A 42 - TB 42
068.880A	86	45	068.880P	74	45	072.880	105	44.5	98x3	016.056	69.5	100	TRAUB A 60
068.881A	86	45	068.881 P	74	67	072.880	105	44.5	98x3	016.043	60	80	TRAUB A 60
068.880A	86	45	068.950P	74	67	072.880	105	44.5	98x3	016.056	69.5	100	TRAUB TB 60
068.881A	86	45	068.951 P	74	89	072.880	105	44.5	98x3	016.043	60	80	TRAUB TB 60
068.920A	54	28	068.920P	40	60	- (3) -	78	40	70x3	016.024	34	56	TRAUB TD 26
068.922A	54	28	068.922P	40	40	- (3) -	78	40	70x3	016.052	34.5	74	TRAUB TD 26

(1) Matice 074.420 lze namontovat na SAIC B26 pokud je na stroji hřídel s válcovým vedením.

(2) Přední pouzdro je dodáváno s maticí.

(3) Pro stroje vyrobeny do r. 1976 kod matice 074.920

(3) Pro stroje vyrobeny po r. 1976 kod matice 074.920 B

## TRUBKA A DISTANČNÍ KROUŽEK



TRUBKA			DISTANČNÍ KROUŽEK			STROJ
KOD	D	L	KOD	D	L	
—	—	—	078.036	27	19.5	BECHLER BR 20
—	—	—	078.140	38.8	20	CASER TA 30
076.210	16.8	165	078.210	16.8	12	FEINLER FA 10
076.220	23	190	078.220	23	12	FEINLER FA 15
076.220	23	190	078.220B	23	10.5	FEINLER FA 15
076.238	26.5	208	078.238	26.5	29.5	GIORGI GM 20
—	—	—	078.245	38.2	26	GIORGI GM 30
076.250	38.5	203	078.250	38.5	26.5	GIORGI GM 32
076.830	32	132	078.601	32.8	26	ITS 26
076.830	32	132	078.600	32.8	24	SAIC B 26
076.830	32	132	078.601	32.8	26	SAIC B 26
076.601	31.7	208	078.601	32.8	26	SAIC A 26
076.610	36.8	128	078.610	37.7	26	SAIC B 30
076.640	56	226	078.640	55.8	21	SAIC B 45

TRUBKA			DISTANČNÍ KROUŽEK			STROJ
KOD	D	L	KOD	D	L	
076.730	16.8	73.5	078.730	16.8	11	STROHM 125
076.731	16.8	73.5	078.731	16.8	11	STROHM 105
—	—	—	078.735	32	26	STROHM 205
—	—	—	078.745	37	27	STROHM 255
076.810	21	156	078.810	21	24	TRAUB A 15 - TC 15
076.811	21	176	078.810	21	24	TRAUB A 15 - TC 15
076.820	28	158	078.820	28	24	TRAUB A 20
076.830	32	132	078.830	32	24	TRAUB A 25
076.830	32	132	078.832	32	26	TRAUB A 25
076.870	51	230	078.870	51	29	TRAUB A 42
076.880	70	234	078.880	70	30	TRAUB A 60
076.920	34	203	078.920	34	15	TRAUB TD 26
—	—	—	078.940	51.8	25	TRAUB TB 42
076.965	22	190	078.965	22	19	UNAMUNO 15

## UPÍNACÍ OBJÍMKY

KOD	D	L	S	H	STROJ	POZ.
079.015	38	50	15.5	14	ATA 25	1
079.016	53	50	19.5	20	ATA40 / SKODA40 / MAS40	1
079.310	24	36	11.6	8	INDEX 12	1
079.315	26	34	12	—	INDEX DG 12	2
079.320	30	34	11.5	10.1	INDEX 12 - ON 12 - OR 12	1
079.330	30	40	13.5	10.5	INDEX 18 - C 19	1
079.340	36	40	13.5	13	INDEX 25	1
079.350	37	42	15.8	13	INDEX 24 - B 30 - C 29	1
079.360	48	52	19.5	18.4	INDEX 36 - B 42	1
079.370	67	52	19.5	27.3	INDEX 52 - B 60	1
079.505	36	30	11.5	12	LOGOS L 24	1
079.506	37	30	12.5	12.5	LOGOS L 25	1
079.510	44	35	16	15	LOGOS L 30	1
079.520	52	35	18	19.5	LOGOS L 42	1
079.525	62	40	18	21	LOGOS L 52	1
079.750	38	50	14.5	11.5	TAREX L 32	1
079.753	47	50	15.5	16	TAREX L 42	1
079.753B	47	50	21.5	16	TAREX L 42	1
079.756	57	50	15.5	21	TAREX L 52	1
079.756B	57	50	21.5	21	TAREX L 52	1
079.762B	70	50	24.5	22.3	TAREX L 64	1

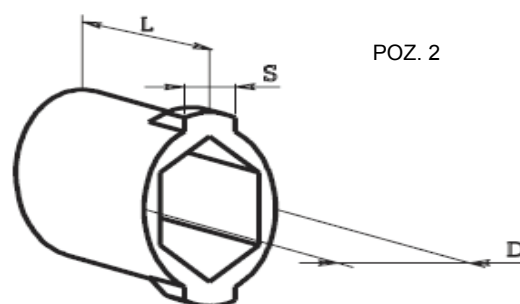
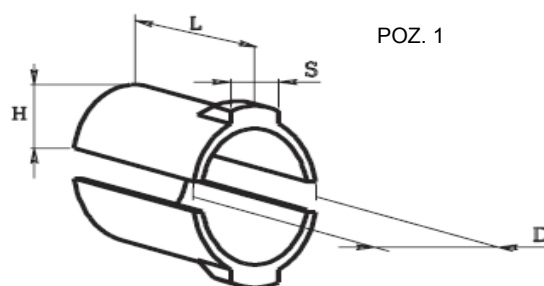

## Náhradní díly pro automatické soustruhy

## POUZDRA UPÍNACÍCH PALCŮ A UPÍNACÍ KROUŽKY

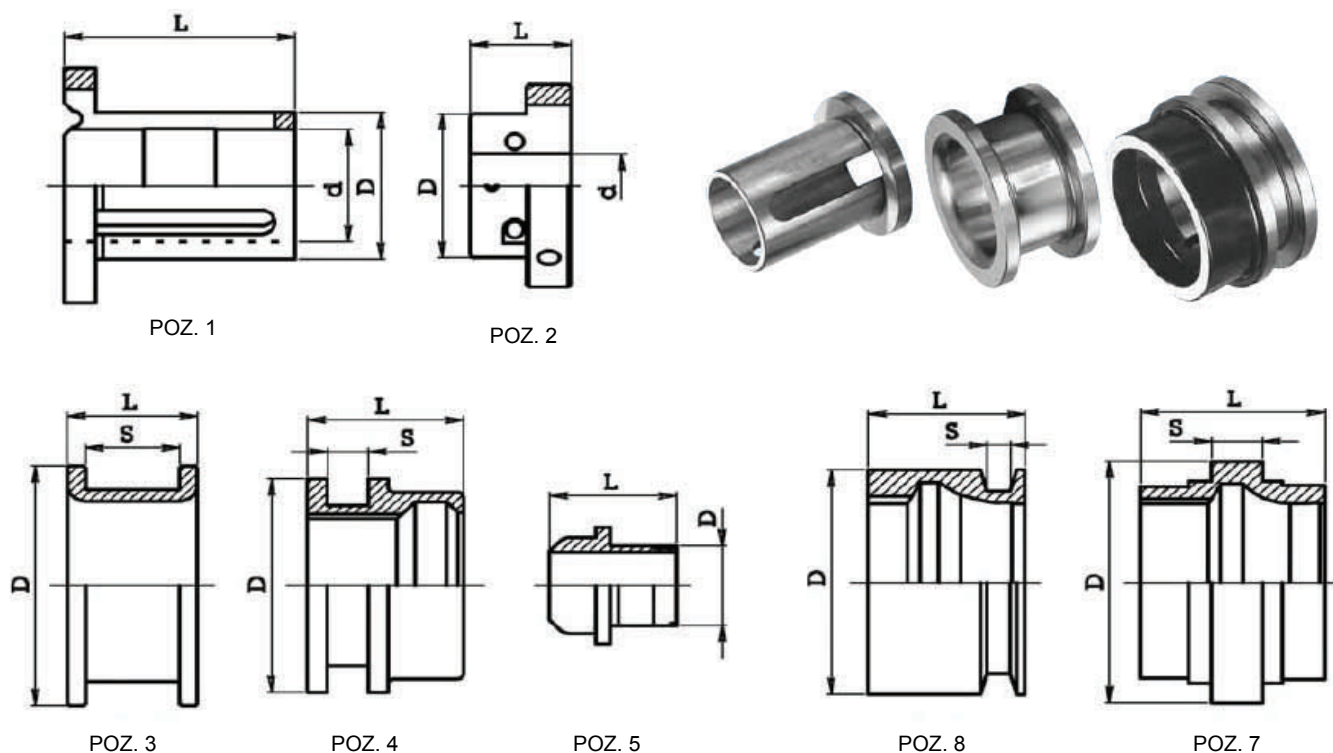

POUZDRO					KROUŽEK					KOD Palce	n°	STROJ
KOD	D	d	L	Poz.	KOD	D	L	S	Poz.			
080.830	50	42	75	1	082.130	80	42	30.5	3	084.130	3	CASER TA 26
080.140	55.5	47	75	1	082.140	85	41	30.5	3	084.130	3	CASER TA 30
080.211	—	—	—	—	080.210	30	43	—	5	084.220	2	FEINLER FA 10
080.221	59	30	45	2	080.220	35	44.5	—	5	084.220	2	FEINLER FA 15
—	—	—	—	—	082.230B	40	64	—	—	—	—	GILDEMEISTER GM16AC(3)
—	—	—	—	—	082.235	115	88	20	4	—	—	GILDEMEISTER GS 25 (1)
—	—	—	—	—	082.235B	115	88	20	4	—	—	GILDEMEISTER GS 25 (2)
080.238	47	35	85	1	082.238	76	43	30	3	084.240	3	GIORGI GM 20
080.250	56	46	85	1	082.250	91	43	30	3	084.240	3	GIORGI GM 32
080.310	46	39	74	1	—	—	—	—	—	084.310	2	INDEX ON 12
080.315	42	35	77	1	—	—	—	—	—	084.310	2	INDEX DG 12
080.320	44	34	72	1	082.320	80	54	14	4	084.320	2	INDEX 12
080.330	50	39	72	1	082.330	80	54	14	4	084.330	2	INDEX 18 - C19
080.340	56	44	72	1	082.340	86	54	14	4	084.330	2	INDEX 25
080.345	60	48	72	1	082.345	90	54	14	4	084.350	2	INDEX C29
080.350	68	48	94	1	082.350	115	76	18	4	084.351	2	INDEX 24 - B30
080.360	80	59	94	1	082.360	115	76	18	4	084.360	2	INDEX 36 - B42
080.370	98	76	94	1	082.370	130	52	18	4	084.360	2	INDEX 52 - B60
080.830	50	42	75	1	082.830	79	45	30.5	3	084.600	3	ITS 26 - (starý typ)
080.420	55	42	80	1	082.420	84	42.5	30.5	3	084.420	3	ITS 26
—	—	—	—	—	082.557	—	—	—	—	—	—	MAS 40
080.830	50	42	75	1	082.830	79	45	30.5	3	084.600	3	SAIC B26
—	—	—	—	—	082.420	84	42.5	30.5	3	—	—	SAIC A30
080.610	55	47	74	1	082.610	81.5	44.3	30.5	3	084.610	3	SAIC B30
080.640	84	67	81	1	082.640	115	47	32.5	3	084.640	3	SAIC B45

(1) 082.235 otvor  $\varnothing$  76 (2) 082.235B otvor  $\varnothing$  72 (3) 082.230B otvor  $\varnothing$  34

## Náhradní díly pro automatické soustruhy

## POUZDRA UPÍNACÍCH PALCŮ A UPÍNACÍ KROUŽKY

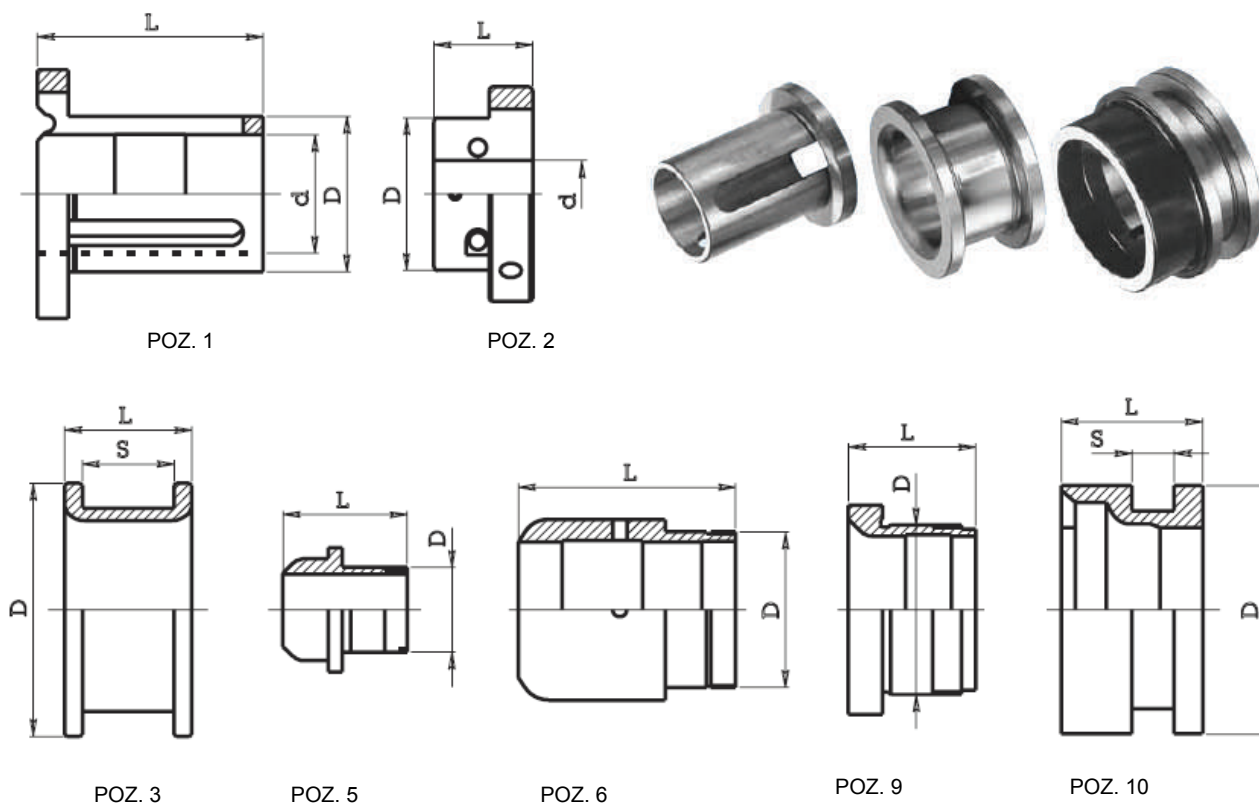

POUZDRO					KROUŽEK					KOD Palce	n°	STROJ
KOD	D	d	L	Poz.	KOD	D	L	S	Poz.			
—	—	—	—	—	082.662	92	65	18	7	—	—	SHUTTE SE 16
—	—	—	—	—	082.662B	85.5	55	8.3	8	—	—	SHUTTE SE 16
—	—	—	—	—	080.728	25	32	—	5	—	—	STROHM 4,5
080.731	76	25	35	2	080.730	30	44	—	5	084.730	2	STROHM 125
—	—	—	—	—	080.735	55	77	—	6	—	—	STROHM 205
—	—	—	—	—	080.740	60	77	—	6	—	—	STROHM 255
080.810	37	30	65.3	1	082.810	57	40	22.5	3	084.810	2	TRAUB A15 (starý typ)
080.811	42	30	72	1	082.811	70	46	30.5	3	084.830	2	TRAUB A15 (Palce POZ.10)
080.812	42	30	72	1	082.811	70	46	30.5	3	084.831	2	TRAUB A15 (Palce POZ.12)
080.812	42	30	72	1	082.800	50	43.5	—	9	084.831	2	TRAUB TC15
080.820	45	38	74	1	082.820	72	46	30.5	3	084.830	3	TRAUB A20
080.830	50	42	75	1	082.830	79	45	30.5	3	084.830	3	TRAUB A25 (Palce POZ.10)
080.831	50	42	75	1	082.830	79	45	30.5	3	084.831	3	TRAUB A25 (Palce POZ.12)
080.850	60	50	73	1	082.850	96.8	45	32.5	3	084.870	3	TRAUB A26
080.860	74	60	75	1	082.860	112	45	32.5	3	084.870	3	TRAUB A36
080.870	79	60	76	1	082.870	112	45	32.5	3	084.870	3	TRAUB A42
080.880	96	80	76	1	082.880	128	45	32.5	3	084.870	3	TRAUB A60
080.920	52	40	78	1	082.920	60	45	—	9	084.920	3	TRAUB TD26
080.940	80	65	90	1	082.940	118	45	32.5	3	084.950	3	TRAUB TB42
080.950	96	82	90	1	082.880	128	45	32.5	3	084.950	3	TRAUB TB60
—	—	—	—	—	082.978	87.3	50	14.5	10	—	—	WICKMAN 5/8
—	—	—	—	—	082.979	112.8	93.6	19.2	10	—	—	WICKMAN 1"
—	—	—	—	—	082.982	144	127	19	10	—	—	WICKMAN 1" 3/8
—	—	—	—	—	082.982B	144	127	19	10	—	—	WICKMAN 1" 3/8
—	—	—	—	—	082.984	170	125	22	10	—	—	WICKMAN 2" 1/4
—	—	—	—	—	080.220	35	44.5	—	5	—	—	UNAMUNO 15

## BRONZOVÝ SEGMENT

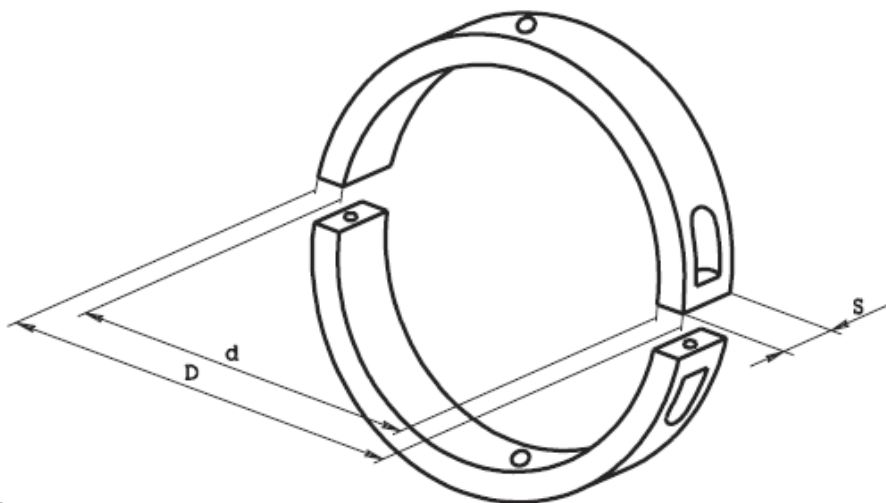

## SEGMENT RYCHLOPOSUVOVÉ SPOJKY

KOD	D	d	S	STROJ
081.320B	100	79	14	INDEX 12
081.330B	101	82	14	INDEX 18-C19
081.340B	106	88	14	INDEX 25
081.345B	113	95	14	INDEX C29
081.350B	136	103	18	INDEX 24
081.355B	136	105	18	INDEX B30
081.360B	136	116	18	INDEX 36-B42
081.370B	152	133	18	INDEX 52-B60

## SEGMENT UPÍNÁNÍ KLEŠTINY

KOD	D	d	S	STROJ
081.330	83	62	14	INDEX 12-18-C19
081.340	90	68.5	14	INDEX 25
081.345	93	72	14	INDEX C29
081.360	118	92	18	INDEX 24-36-B30-B42
081.370	133	110	18	INDEX 52-B60

## PALCE PRO SPOJKY

## POZ. 1

KOD	A	F	H	L	S	STROJ
083.340B	6	5x0.5	14	39.5	12	INDEX 12-18-25 - C19 (A33091)
083.343B	8	5x0.5	16	45.5	16	INDEX 24-E26-ER26 Spojka INDEX B30 (A53090)
083.345B	6	5x0.5	16	39.5	12	INDEX C29 (C29381)
083.360B	8	5x0.5	20	45.5	16	INDEX 36-52 - Převodovka IN- DEX B42-60 (A73090)
083.361B	7	5x0.5	20	40.2	10	Převodovka INDEX B30 - Spojka INDEX B42-60-B60F (AR1840)

## ŠROUB

KOD	šroub	Pro KOD
083.340 956	T9 ø5 L=6	083.340B - 083.345B
083.343 959	T9 ø5 L=9	083.343B - 083.360B
083.361 856	T8 ø5 L=6	083.361 B

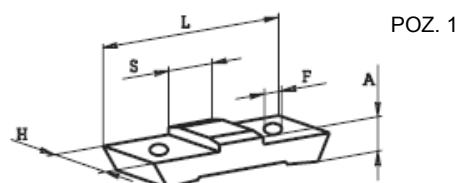

## POZ. 2

KOD	A	F	H	L	S	STROJ
083.340	17	7	13.8	45	12	INDEX 12-18-25 - C19 (A33060)
083.343	20	8	15.8	50	14	INDEX 24-E26-ER26
083.344	18	8	15.8	50	14	Spojka INDEX B30 (A53060)
083.345	17	7	15.8	45	12	INDEX C29 (C29331)
083.360	20	8	19.8	50	14	INDEX 36-52 Převodovka INDEX B42-60 (A73060)
083.361	22	8	19.8	46	14	Převodovka INDEX B30 - Spojka INDEX B42-60-B60F (AR1830)

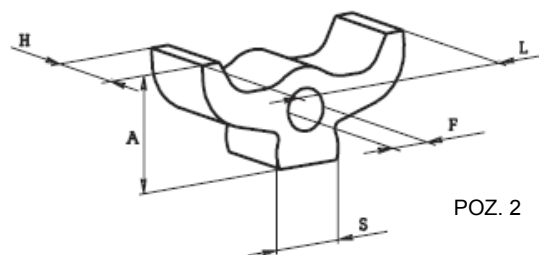

## Náhradní díly pro automatické soustruhy

## UPÍNACÍ PALCE

KOD	S	L	F	H	Poz.	STROJ	Poč.
084.007	15	84	—	30	1	AKEBONO MINC-26	
084.015	15.5	103.5	—	26.7	2	ATA 25	2
084.016	19.5	103.5	—	26.7	2	ATA 40	2
084.019	10	92	8	28	22	BECHET 19	
084.028	6	54.5	3	16	3	BECHLER A7-A10	2
084.028B	6	54.5	4	16	3	BECHLER A7-A10	2
084.039B	12	76.2	6	28.6	4	BECHLER B20 (nový typ)	2
084.050	14.5	55	8	24	5	BODEM P26-32	2
084.069	12.5	61	—	15.5	2	BROWN e SHARPE 00	2
084.076	9.5	53	6.35	12.6	6	BSA ACME-GRIDLEY 5/16-7/16	
084.077	15.9	66.5	8.34	19	6	BSA ACME-GRIDLEY 1"	
084.100	19.8	75	3	20	7	CAMPONESI A42-60	3
084.130	9	70	—	18	7	CASER TA26-30	3
084.145	12	92.5	—	26	8	CASER TA45	3
084.150	14.5	92.5	—	26	8	CASER TA50	3
084.162	6	52	4	17.5	21	CITIZEN G16	
084.162B	10	72,3	8	24	21	CITIZEN 32	
084.162C	8	55	6	20.2	29	CITIZEN L20	
084.166	8	60	7	24	9	CERIOTTI RV32	2
084.169	6	50	6.35	18.3	38	CONOMATIC 9/16	
084.175B	25	84	8	30	10	DAR 46	2
084.175	25	84	10	30	10	DAR 71	2
084.176	30	100.5	10	38	10	DAR 90	2
084.182	10	68	10	30.2	9	DIEMME-FERRI 26	2
084.220	7	50	6	19	11	FEINLER FA10-FA15	2
084.224	6	57	4	15.5	3	GAUTHIER GM12-15	2
084.229	9	62	—		12	GILDEMEISTER AS12	18
084.230	9	67.5	—	19.2	12	GILDEMEISTER AS16-20	18
084.230A	11.5	67.8	—		12	GILDEMEISTER GS20/6	18
084.230B	8	60.5	8		38	GILDEMEISTER GM16 AC	18
084.230C	10	53.5	7		11	GILDEMEISTER GD16 (dlouhotočný)	18
084.230D	10	58	7	25	—	GILDEMEISTER GLD20-25-32	
084.230E	10	52.6	7	28.6	—	GILDEMEISTER GD20	
084.230F	10	58	—	23.5	—	GILDEMEISTER GD20	
084.230G	10	54.5	—	29.1	—	GILDEMEISTER GD32-SPRINT32	
084.230H	10	54	7	25.5	—	GILDEMEISTER SPRINT42	
084.230-9	13	99	10	32	—	GILDEMEISTER SPRINT42	
084.231	20	65	—	21.8	16	GILDEMEISTER AS25 (německý)	18
084.232A	24	73	—	23.5	13	GILDEMEISTER AS32	18
084.232B	24	73	—	24	14	GILDEMEISTER AS32	18
084.232C	24	73	—	25	15	GILDEMEISTER AS32	18
084.232D	24	66	—	25	16	GILDEMEISTER AS32	18
084.233	8	54	—	14	12	GILDEMEISTER ASL10	
084.234A	30	73	—	25	13	GILDEMEISTER AS48	18
084.234B	30	80	—	24.5	14	GILDEMEISTER AS48	18
084.234C	30	80	—	25.7	15	GILDEMEISTER AS48	18
084.234D	30	74	—	25.7	16	GILDEMEISTER AS48	18
084.235	13	34	—	15.4	17	GILDEMEISTER AS28	18

S = Síla  
L = Délka  
F = Průměr otvoru  
H = Výška

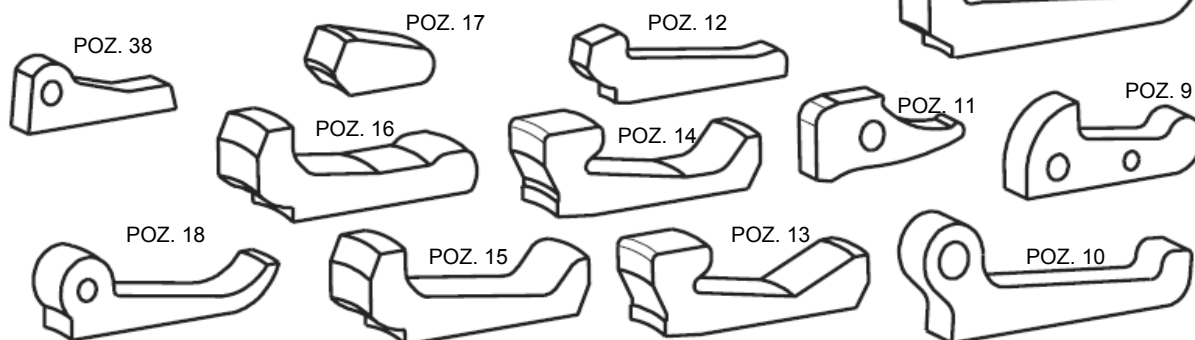
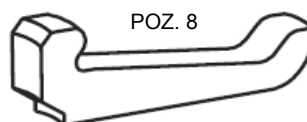
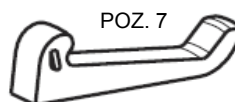
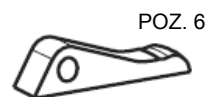
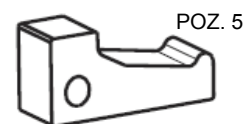
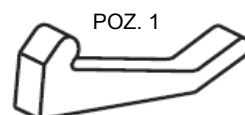

## Náhradní díly pro automatické soustruhy

## UPÍNACÍ PALCE

KOD	S	L	F	H	Poz.	STROJ	Poč.
084.240	10	74	6	22	18	GIORGI GM 20-25-30-32	3
084.260 012	12	57	—	17		HANWA	
084.261 014	14	85.8	—	23		HANWA STL 32-35	
084.260B	12	57,9	—	17	2	MANURHIN K'MX413	2
084.270	12	75	—	25	7	IMAMI IC16-R28	
084.310	11.8	66	—	17.2	2	INDEX ON12-OR12-DG12	2
084.311	13.8	66	—	17.2	2	INDEX E25 hydraulika	2
084.320	11.8	74	—	20	2	INDEX 12	2
084.330	13.5	74	—	20	2	INDEX 18-25-C19 - ER25	2
084.350	15.5	74	—	20	2	INDEX C29	2
084.351	15.5	100	—	24.2	2	INDEX 24-B30	2
084.360	19.8	100	—	24.2	2	INDEX 36-52-B42-B60	2
084.366	20	88	—	23		INDEX KS 32-42-50	
084.420	10	73	6	19.5	19	ITS 26	3
084.450	17.5	88	8	28	20	ITS 36-42-60	3
084.465	8	73	—	18.3	7	K.HOFFMAN H15 K.HUNGER 15	2
084.330	13.5	74	—	17.2	2	LOGOS L18-L24	2
084.457	15.5	98	3	27		YATOR 42	
084.480	10	70	3	26		LANGE T35	
084.510	15.5	100	—	24.2	2	LOGOS L30	2
084.520	18.4	100	—	24.2	2	LOGOS L36-42-52	2
084.530	21.3	100	—	24.2	2	LOGOS L64	2
084.532	25	100	—	24.2	2	LOGOS L68	2
084.543	12	70.6	7	24	10	MANURHIN PF TR 22-25	
084.549	15.5	91	10	32.5	10	MANURHIN PF TR 32-42	
084.558	11	53	—	17	7	MAURI 20	3
084.560	10	58.6	6	21.5		MIYANO BJ26	
084.600	10	71	—	18	7	ITS 26 TCA301 (starý typ)	3
084.570	6	35	3	14.2	21	PETERMAN P4	2
084.571	7	55	4	16.2	3	PETERMAN P7	2
084.572	7	68	4	19	3	PETERMAN P7R	2
084.572B	7	68	5	19	3	PETERMAN P7R	2
084.577	10	99	5	22	22	PETERMAN P16	2
084.581	26	120	12	28		PITTLER PRC 50/6	
084.583	14	76	10	32	37	RECORD 42	
084.584	8.5	60	—	18	2	ROTARIX 20-25-30-32	
084.600	10	71	—	18	7	SAIC B26	3
084.610	12.4	72.5	2	18	7	SAIC B30	3
084.620	14.5	73	6	24.5	24	SAIC A26-30-32-35	
084.621	14.5	73	6	26.5	24	SAIC A26-30-32	
084.622	14.5	73	6	20	23	SAIC A26-30-32	
084.630	10	53	8	28	9	SAIC DP5/26	2
084.640	14.5	82	2.5	23.5	7	SAIC B45	3
084.650	12	62.2	—	19	25	SCHAUBLIN 102-120HP	

S = Síla  
L = Délka  
F = Průměr otvoru  
H = Výška



POZ. 2



POZ. 3

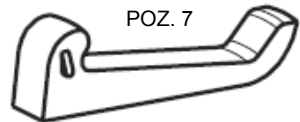

POZ. 7

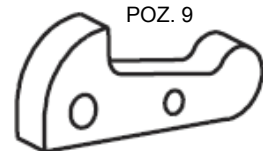

POZ. 9

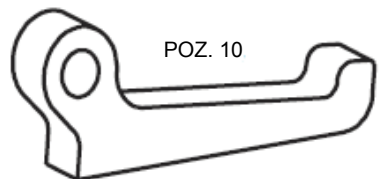

POZ. 10

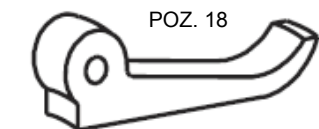

POZ. 18

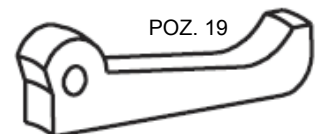

POZ. 19

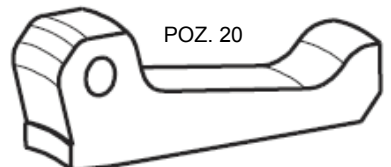

POZ. 20



POZ. 21

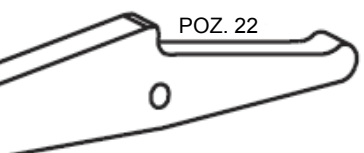

POZ. 22

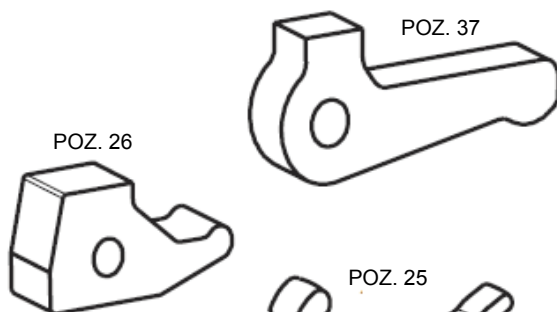

POZ. 26

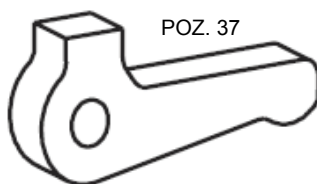

POZ. 37



POZ. 23



POZ. 25



POZ. 24

## Náhradní díly pro automatické soustruhy

## UPÍNACÍ PALCE

KOD (Code)	S	L	F	H	Poz.	STROJ	Poč.
084.662	13.5	58	—	18	27	SCHUTTE SE16	18
084.664	13.5	59	—	18.5	27	SCHUTTE SE25 - SD25	18
084.665	18	93	—	26.2	28	SCHUTTE SE32 - VD32 - SD32	18
084.680	10	73	6	27		STAR NC16	
084.683	12	50	8	25.5	26	STAR KNC 32B - SNR32	
084.683B	14	69.1	8	30	26	STAR KNC 32	
084.686	12	67.5	2.5	18.8	2	STEINHAUSER STF16	
084.688	12	68	8	23	10	STEINHAUSER STF25	
084.690	14	81	3	22.2	2	STEINHAUSER STF36	
084.720	6	44	4.5	16	29	STROHM 45	2
084.730	7	50	6	21	11	STROHM 125NAR	2
084.730B	7	50	6	21	11	STROHM 75-105-125AS	2
084.731	7	50	8	21	11	STROHM 125NAR s čepy	2
084.731B	7	50	8	21	11	STROHM 75-105-125AS s čepy	2
084.740	12	90.5	9	31	3	STROHM 205-255 (starý typ)	2
084.745	13.8	92	8	26	30	STROHM 205-255 (nový typ)	2
084.762	25	76	10	37	31	TAREX TH64	2
084.530	21.5	100	—	24.2	2	TAREX L32-42-52	2
084.351	15.5	100	—	24.2	2	TAREX L42-52-64	2
084.770	12	85	8	28		TOBRE 20	
084.790	6	43	4.5	16	3	TORNOS T4	2
084.792	7	60	5	18.3	32	TORNOS M7	2
084.792B	7	60	6	18.3	32	TORNOS M7	2
084.793	7	62.8	5	18	3	TORNOS MS7	2
084.794	11.8	66	—	17.2	2	TORNOS R7-R10	2
084.795	9	71.3	7	24.3	32	TORNOS M15	2
084.795B	9	55	6	21.3	3	TORNOS NA12	2
084.796	13.5	74	—	20	2	TORNOS R16	2
084.798	12	91	8	30	32	TORNOS 20	
084.799	12	103	8	30	32	TORNOS 25	
084.810	9	62	—	17	7	TRAUB A15 (starý typ)	2
084.830	10	70	—	18	7	TRAUB A15	2
084.830	10	70	—	18	7	TRAUB A20-25	3
084.831	12	70	—	18	7	TRAUB A15	2
084.831	12	70	—	18	7	TRAUB A20-25 TC15	3
084.870	14	72	—	20.7	7	TRAUB A26-36-42-45-60	3
084.920	12	75	2	18.3	33	TRAUB TD16-26-36	3
084.950	18	84	—	22	34	TRAUB TB30-42-60	3

S = Síla  
L = Délka  
F = Průměr díry  
H = Výška

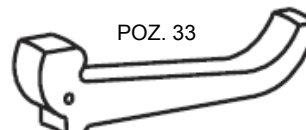
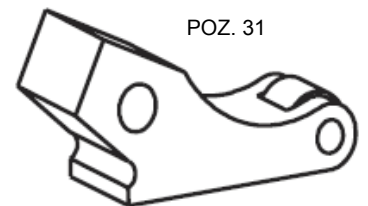
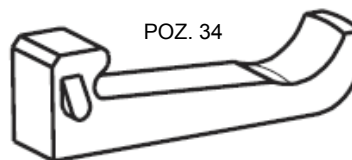
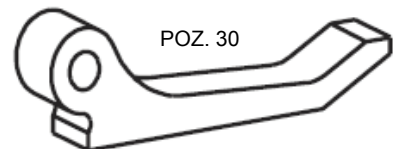
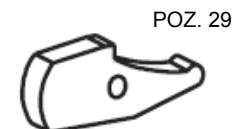
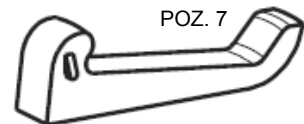
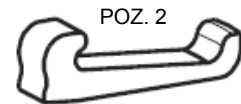

## UPÍNACÍ PALCE

S = Síla  
L = Délka  
F = Průměr díry  
H = Výška

KOD	S	L	F	H	Poz.	STROJ	Poč.
084.958	12	57	—	17	2	TSUGAMI S20-BS20 BE dlouhotočný	
084.958B	8	56	—	13	2	TSUGAMI S20-BS20 BE protivřetenno	
084.958	12	57	—	17	2	TSUGAMI NP20-BS20 BE protivřetenno	
084.958C	7,94	51	—	14,14	2	TSUGAMI L10	
084.959	12	85	—	22	2	TSUGAMI NP20 dlouhotočný HANWHA 26 - TSUGAMI MORI BS32	
084.220	7	50	6	19	11	UNAMUNO 15	
084.350	15.5	74	—	20	2	UNAMUNO 25	
084.958 008	8	57	—	17	2	HANWA	
084.968	11.5	70	8	29.4	24	UNIMAT 25	
084.978	18.25	56.35	7.93	19.2	35	WICKMAN 5/8" (6 vřeten.)	12
084.979	18.25	77	11.11	26.1	35	WICKMAN 1"	12
084.979B	7	72.9	6	25		WICKMAN B32	
084.982	27.8	100	14.28	35.7	35	WICKMAN 1" 3/8 (5 - 6 vřeten.)	12
084.990	7	67.8	4	16.5	36	WIRT GRUFFAT TCN12	
084.990B	7	67.8	5	16.5	36	WIRT GRUFFAT TCN12	

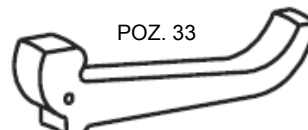
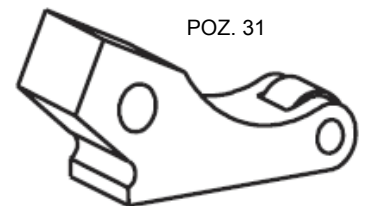
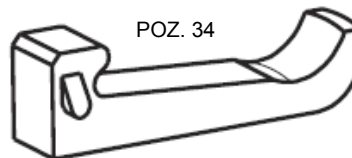
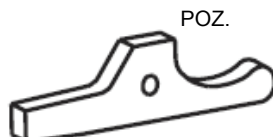
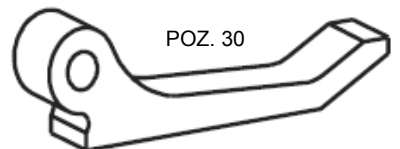
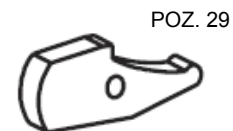
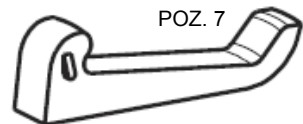
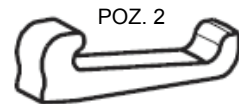

Náhradní díly pro automatické soustruhy

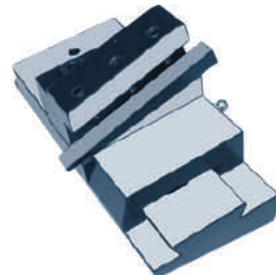
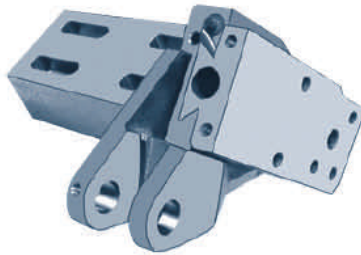
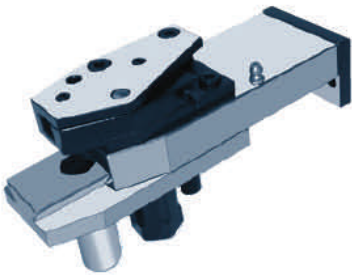

## POLOTOVARY VAČEK

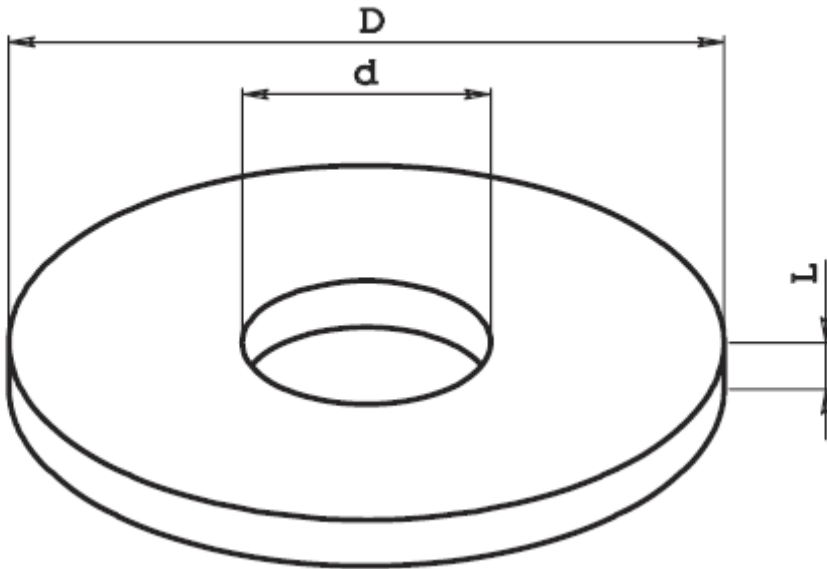

KOD	D	d	L
400.140 4010	140	40	10
400.140 4508	140	45	8
400.140 5010	140	50	10
400.150 3608	150	36	8
400.150 4010	150	40	10
400.150 5010	150	50	10
400.156 2808	156	28	8
400.158 4810	158	48	10
400.158 5810	158	58	10
400.160 2008	160	20	8
400.160 2408	160	24	8
400.160 2410	160	24	10
400.160 2610	160	26	10
400.160 2808	160	28	8
400.160 3006	160	30	6
400.160 3208	160	32	8
400.160 4010	160	40	10
400.160 4512	160	45	12
400.166 3208	166	32	8
400.170 3510	170	35	10
400.170 4010	170	40	10
400.175 3510	175	35	10
400.180 2008	180	20	8
400.180 3208	180	32	8
400.180 4010	180	40	10
400.190 4010	190	40	10
400.200 2008	200	20	8
400.200 2410	200	24	10
400.200 2610	200	26	10
400.200 3010	200	30	10
400.200 3208	200	32	8
400.200 3608	200	36	8
400.200 4010	200	40	10
400.210 2410	210	24	10
400.220 2010	220	20	10
400.220 2410	220	24	10
400.220 2610	220	26	10
400.220 3208	220	32	8
400.220 4010	220	40	10
400.240 2010	240	20	10
400.240 4010	240	40	10
400.250 2610	250	26	10
400.250 4010	250	40	10
400.260 2810	260	28	10
400.260 2812	260	28	12
400.260 4010	260	40	10
400.270 4010	270	40	10
400.280 4010	280	40	10
400.300 4010	300	40	10

KOD	D	d	L
400.078 3010	78	30	10
400.080 4610	82	46	10
400.086 4610	86	46	10
400.088 3010	88	30	10
400.088 4610	88	46	10
400.089 3012	89	30	12
400.090 2008	90	20	8
400.090 3006	90	30	6
400.090 4510	90	45	10
400.092 3006	92	30	6
400.096 4012	98	40	12
400.096 4410	96	44	10
400.099 4012	99	40	12
400.100 2408	100	24	8
400.100 2410	100	24	10
400.100 2808	100	28	8
400.100 3010	100	30	10
400.106 3010	106	30	10
400.106 30 12	106	30	12
400.110 2008	110	20	8
400.110 2606	110	26	6
400.110 2808	110	28	8
400.110 3208	110	32	8
400.110 4206	110	42	6
400.110 4512	110	45	12
400.110 4612	110	46	12
400.115 3006	115	30	6
400.115 3010	115	30	10
400.118 5812	118	58	12

KOD	D	d	L
400.120 2008	120	20	8
400.120 2410	120	24	10
400.120 2610	120	26	10
400.120 2808	120	28	8
400.120 3006	120	30	6
400.120 3007	120	30	7
400.120 3208	120	32	8
400.120 4010	120	40	10
400.123 6412	123	64	12
400.124 3208	124	32	8
400.124 4208	124	42	8
400.125 2008	125	20	8
400.125 2608	125	26	8
400.125 2808	125	28	8
400.125 3208	125	32	8
400.125 4208	125	42	8
400.130 2008	130	20	8
400.130 3006	130	30	6
400.130 3208	130	32	8
400.130 4008	130	40	8
400.130 4208	130	42	8
400.130 4512	130	45	12
400.140 2008	140	20	8
400.140 2410	140	24	10
400.140 2610	140	26	10
400.140 2808	140	28	8
400.140 3008	140	30	8
400.140 3208	140	32	8
400.140 3608	140	36	8

## Náhradní díly pro automatické soustruhy

## POLOTOVARY BUBNOVÝCH VAČEK

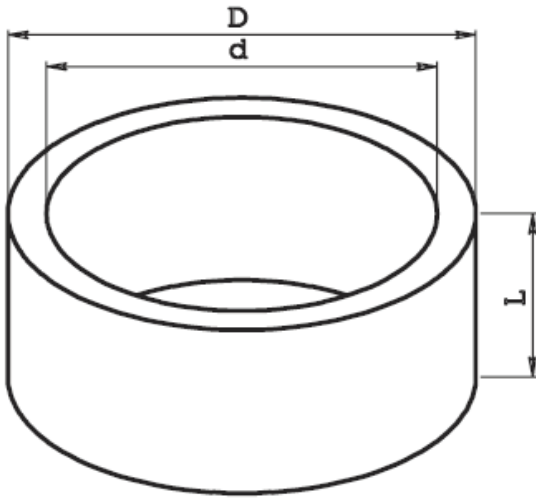

KOD	L	D	d	STROJ	FUNKCE
402.040	40	80	60	TRAUB A15-20-25 SAIC B26-30 A30 ITS 26 GIORGI 20-25-32 CASER 26	SOUSTRUŽENÍ
402.050	50				
402.060	60				
402.070	70				
402.080	80				
402.090	90				

KOD	L	D	d	STROJ	FUNKCE
403.050	50	99	78	CASER 26-30 CASER 26-30 MERLI 26 MERLI 26	PODEPŘENÍ ZÁVITOŘEZ PODEPŘENÍ ZÁVITOŘEZ
403.060	60				
403.070	70				
403.075	75				
403.080	80				

KOD	L	D	d	STROJ	FUNKCE
404.030	30	108	84	SAIC B26-30 SAIC A30 ITS 26	ZÁVITOŘEZ
404.040	40				
404.050	50				
404.060	60				
404.070	70				
404.080	80				
404.090	90				
404.100	100				

KOD	L	D	d	STROJ	FUNKCE
405.025	25	104	80	GIORGI GM 20-25-32	ZÁVITOŘEZ
405.035	35				
405.040	40				
405.050	50				
405.060	60				
405.070	70				
405.080	80				
405.090	90				

KOD	L	D	d	STROJ	FUNKCE
406.040	40	108	88	SAIC B26-30 A30 ITS 26 GIORGI 20-25-32	PODEPŘENÍ
406.050	50				
406.060	60				
406.070	70				
406.080	80				
406.090	90				
406.100	100				
406.120	120				

KOD	L	D	d	STROJ	FUNKCE
407.040	40	120	104	STROHM 105-125	3 VŘETENA
407.045	45				
407.050	50				
407.060	60				
407.070	70				
407.080	80				

KOD	L	D	d	STROJ	FUNKCE
408.040	40	115	95	TRAUB A15-20-25 TRAUB A15-20-25 TRAUB A36-42-60	PODEPŘENÍ ZÁVITOŘEZ SOUSTRUŽENÍ
408.050	50				
408.060	60				
408.070	70				
408.080	80				
408.090	90				
408.100	100				
408.110	110				
408.120	120				

KOD	L	D	d	STROJ	FUNKCE
410.040	40	130	110	TRAUB TD16-26-36	PODEPŘENÍ REV. HLAVA
410.050	50				
410.060	60				
410.070	70				
410.080	80				
410.090	90				
410.100	100				
410.110	110				
410.120	120				
410.130	130				
410.140	140				

KOD	L	D	d	STROJ	FUNKCE
412.050	50	150	125	TRAUB A42-60 TRAUB A42-60 TRAUB TB42-60 TRAUB TB42-60 SAIC B45 ITS 36-42-60 ITS 36-42-60	PODEPŘENÍ REV. HLAVA REV. HLAVA SOUSTRUŽENÍ PODEPŘENÍ PODEPŘENÍ SOUSTRUŽENÍ
412.060	60				
412.070	70				
412.080	80				
412.090	90				
412.100	100				
412.110	110				
412.120	120				
412.130	130				
412.140	140				
412.150	150				





## Náhradní díly pro automatické soustruhy

## VAČKY PRO PODÉLNÉ SOUSTRUŽENÍ

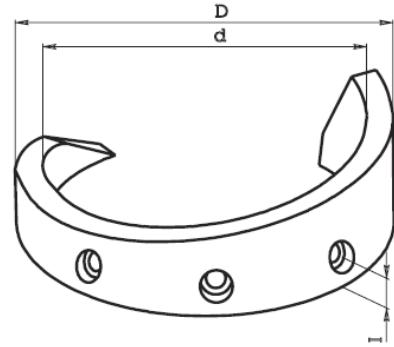

KOD	Stup.	dráha												D = 80	d = 60	l = 10	STROJ	
430.101	180°	10	15	20	25	30	35	40	50									TRAUB A1 5-20-25
430.101	220°	10	15	20	25	30	35	40	50	60								CASER TA26-30
430.101	240°			20		30		40	50	60								SAIC B26-30 A26-30-32 GIORGI 20-25-30-32 ITS 26

KOD	Stup.	dráha												D = 115	d = 95	l = 15	STROJ	
430.601	180°	10	20	30	40	50	60											TRAUB A26-36-42-60
430.601	220°	10	20	30	40	50	60	70										
430.601	240°			40		60		80										

## VAČKY PRO VRTÁNÍ A PRO ŘEZÁNÍ ZÁVITŮ

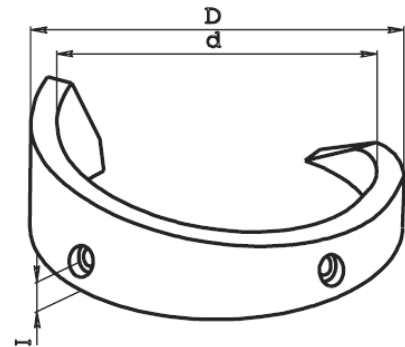

KOD	Stup.	dráha												D = 115	d = 95	l = 15	STROJ	
431.101	100°	5	8	10	12	15	18	20	23	25	30	35						TRAUB A1 5-20-25
431.101	120°	5	8	10	12	15	18	20	23	25	30	35	40					

KOD	Stup.	dráha												D = 104	d = 80	l = 11	STROJ	
431.201	90°	6	8	10	12	15	18	20	23	25	30							G IORG I 20-25-30-32
431.201	120°	6	8	10	12	15	18	20	23	25	30	35						

KOD	Stup.	dráha												D = 108	d = 84	l = 11	STROJ	
431.202	100°	5	8	10	12	15	18	20	22	25	28	30	35					SAIC B26-30 A26-30-32 ITS 26 starý typ
431.202	120°	5	8	10	12	15	18	20	22	25	28	30	35					

KOD	Stup.	dráha												D = 108	d = 88	l = 15	STROJ	
431.203	100°	10	12	15	18	20	22	25	28	30	35							ITS 26 nový typ
431.203	120°	10	12	15	18	20	22	25	28	30	35							

## Náhradní díly pro automatické soustruhy

## VAČKY PRO VRTÁNÍ A PRO PŘEKLÁPĚNÍ ZÁVITOŘEZU

KOD	D	d	S	STROJ
425.101A	90	36	5	TRAUB A 15-20-25
425.101B	90	36	5	TRAUB A 15-20-25

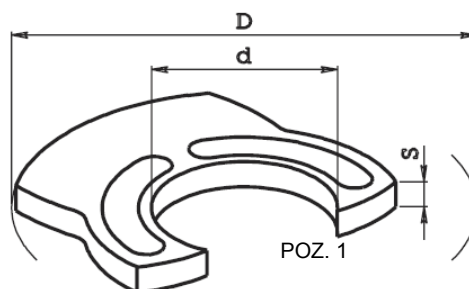

KOD	Stup.	dráha	D	d	S	STROJ
425.201	120°	C 0	88	30	10	SAIC B 26-30
425.201	150°	C 0				
425.201	180°	C 0				
425.201	220°	C 0				
425.204	120°	C 0	106	30	12	ITS 26
425.204	150°	C 0				
425.204	180°	C 0				
425.204	220°	C 0				

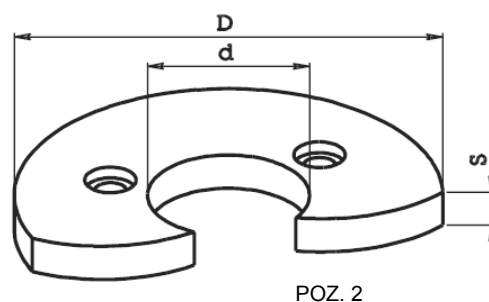

## VAČKY PRO ZÁVITOŘEZ

KOD	Stup.	H	D	d	l	STROJ
432.101	40°	30	115	95	15	TRAUB A 15-20-25
432.101	50°					
432.101	60°					
432.101	70°					
432.101	80°					
432.101	100°					

KOD	Stup.	H	D	d	l	STROJ
432.203	40°	30	108	88	15	ITS 26
432.203	50°					
432.203	60°					
432.203	80°					
432.203	80°					

KOD	Stup.	H	D	d	l	STROJ
432.201	40°	24	104	80	11	GIORGI 20-25-30-32
432.201	50°					
432.201	60°					
432.201	70°					
432.201	80°					
432.201	100°					

KOD	Stup.	H	D	d	l	STROJ
432.202	40°	30	108	84	11	SAIC B26-30 SAIC A26-30-32
432.202	50°					
432.202	60°					
432.202	70°					
432.202	80°					
432.202	100°					

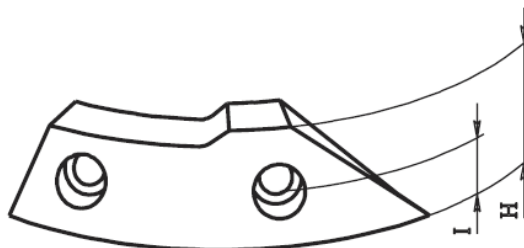



## VAČKY KOTOUČOVÉ A BUBNOVÉ NA DOTAZ

KOD	D	d	S	SUPPORT	STROJ	Poz.
418.240	240	40	10	REVOLVER.HLAVA	ATA 40	10
417.150	150	40	10	PŘÍČNÝ	ATA 40	4
433.203	99	78	10	PODEPŘENÍ - ZÁVITOŘEZ - SOUSTRUŽENÍ	CASERTA 26-30	6
433.243	115	90	16	PODEPŘENÍ - ZÁVITOŘEZ - SOUSTRUŽENÍ	CASERTA 45-50	6
418.240	240	40	10	REVOLVER.HLAVA	DAR 46	10
417.180	180	40	10	SVISLÝ - PŘÍČNÝ	DAR 46	4
433.220	100	81	—	PODEPŘENÍ	FEINLER 10-15	8
422.202	96	44	10	SVISLÝ	GIORGI 20-25-32	1
418.120	120	30	6	REVOLVER.HLAVA	INDEX DG 12	10
418.090	90	30	6	SVISLÝ - PŘÍČNÝ	INDEX DG 12	4
418.166	166	32	8	REVOLVER.HLAVA	INDEX 12-18-25	10
417.125	124	42	8	SVISLÝ	INDEX 12-18-25	4
417.125B	124	32	8	PŘÍČNÝ	INDEX 12-18-25	4
418.220	220	32	8	REVOLVER.HLAVA	INDEX C 19-29	10
417.140	140	36	8	SVISLÝ - PŘÍČNÝ	INDEX C 19-29	4
418.240	240	40	10	REVOLVER.HLAVA	INDEX 24-36-52	10
418.240	240	40	10	REVOLVER.HLAVA	INDEX B 42-60	10
417.150	150	50	10	SVISLÝ	INDEX 24-36-52	4
417.150B	150	40	10	PŘÍČNÝ	INDEX 24-36-52	4
417.150B	150	40	10	SVISLÝ - PŘÍČNÝ	INDEX B 42-60	4
422.205	110	45	12	SVISLÝ	ITS 36	1
418.240	240	40	10	REVOLVER.HLAVA	LOGOS 42-52	10
417.150	150	40	10	PŘÍČNÝ	LOGOS 42-52	4
422.801	123	64	12	SVISLÝ	SAIC B 45	1
421.805	115	48	12	PŘÍČNÝ	SAIC 50	1
433.809	139	115	13	CONTROPUNTA	SAIC 50	5
417.125C	125	28	8	SVISLÝ	STROHM 75-125	3
419.180	180	20	8	VŘETENÍK	STROHM 75-125	11
417.125D	125	20	8	BASCULA	STROHM 75-125	3
419.260	260	26	10	VŘETENÍK	STROHM 205-255	11
417.175B	175	26	10	BASCULA	STROHM 205-255	3
417.175	175	35	10	SVISLÝ	STROHM 205-255	3
418.240	240	40	10	REVOLVER.HLAVA	TAREX 42-52	10
417.150	150	40	10	PŘÍČNÝ	TAREX 42-52	4
421.103	130	40	8	SVISLÝ - PŘÍČNÝ	TRAUB TD 16-26-36	2
433.103	130	110	12.5	PODEPŘENÍ	TRAUB TD 16-26-36	5
434.130	130	110	12.5	REVOLVER.HLAVA	TRAUB TD 16-26-36	7
435.090	90	70	—	ZÁVITOŘEZ	TRAUB TD 16-26-36	9
434.115	115	95	15	REVOLVER.HLAVA	TRAUB A 25	7
434.150	150	125	20	REVOLVER.HLAVA	TRAUB TB 30-42-60	7
435.120	120	95	—	ZÁVITOŘEZ	TRAUB TB 30-42-60	9

POZ. 1



POZ. 2



POZ. 3



POZ. 4



POZ. 5

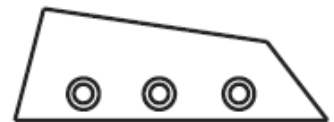

POZ. 6

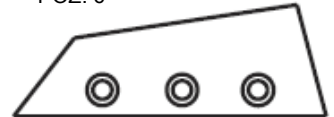

POZ. 8



POZ. 9



POZ. 7



POZ. 11

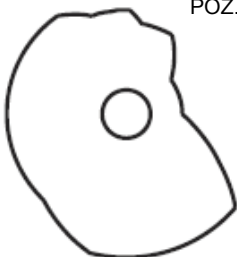

POZ. 10



## UNAŠEČ VAČKY

KOD	D	d	Poz.	SUPPORT	STROJ
500.001	40	30	3	PŘÍČ - SVISL.	TRAUB TD16-26-36
500.101	30	25	1	PŘÍČNÝ	TRAUB A15-20-25
500.102	45	25	1	SVISLÝ	TRAUB A15-20-25
500.103	36	25	1	ZÁVITOŘEZ	TRAUB A15-20-25
500.201	30	25	1	PŘÍČNÝ	SAIC B26 / ITS 26
500.202	46	25	1	SVISLÝ	SAIC B26 / ITS 26
500.601	40	32	1	PŘÍČNÝ	TRAUB A36-42-60
500.602	58	32	1	SVISLÝ	TRAUB A36-42-60
500.701	45	35	1	PŘÍČ - SVISL.	TRAUB TB42-60
500.315	50	30	2	PŘÍČNÝ	INDEX DG 12
500.340	56	32	2	PŘÍČNÝ	INDEX 12-18-25
500.340B	66	42	2	SVISLÝ	INDEX 12-18-25
500.345	60	36	2	PŘÍČ - SVISL.	INDEX C19-29
500.360	68	40	2	PŘÍČNÝ	INDEX 36-52
500.360	68	40	2	PŘÍČ - SVISL.	INDEX B42-60
500.360B	78	50	2	SVISLÝ	INDEX 36-52

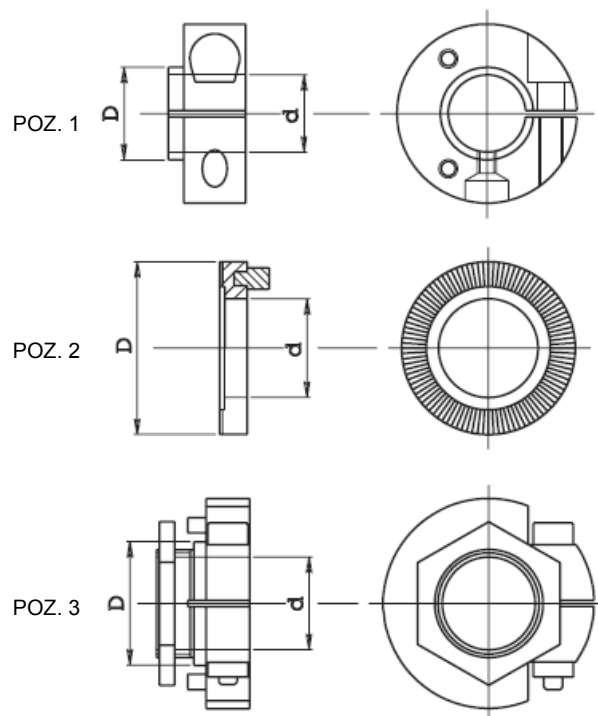

## KOMPLETNÍ VAČKOVÁ HŘÍDEL

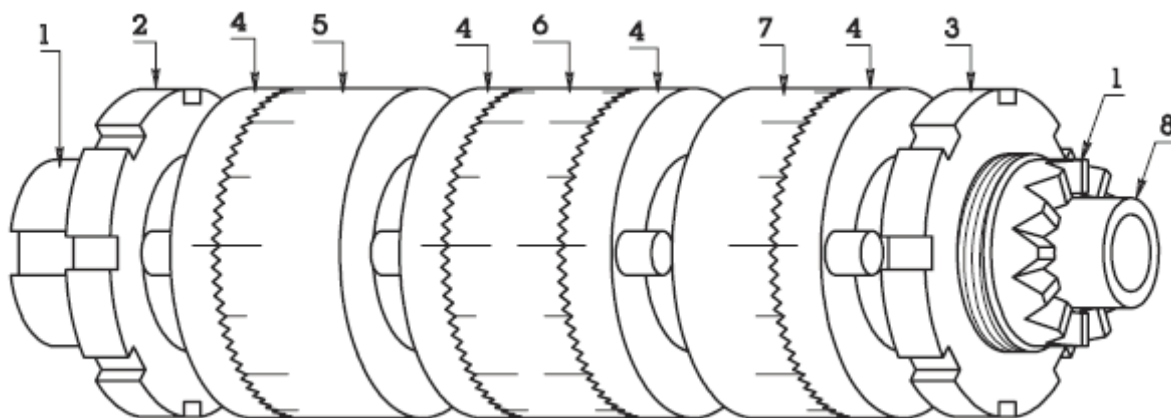

Číslo	POPIS	KOD INDEX C 19-29	KOD INDEX B 30-42-60
	<b>KOMPLETNÍ VAČKOVÁ HŘÍDEL OD č.1 - č.8</b>	<b>686.345</b>	<b>686.360</b>
1	HŘÍDEL	686.345A	686.360A
2	MATICE LEVÝ ZÁVIT	593.345S	593.360S
3	MATICE PRAVÝ ZÁVIT	593.345D	593.360D
4	OZUBENÝ KROUŽEK PRO PŘÍČNÉ VAČKY	500.345	500.360
5	OZUBENÝ KROUŽEK	500.345D	500.360D
6	OBOUSTRANNÝ OZUBENÝ KROUŽEK	500.345E	500.360E
7	OZUBENÝ KROUŽEK	500.345C	500.360C
8	VODÍCÍ POUZDRO	686.345B	686.360B

## UNAŠEČE VAČEK

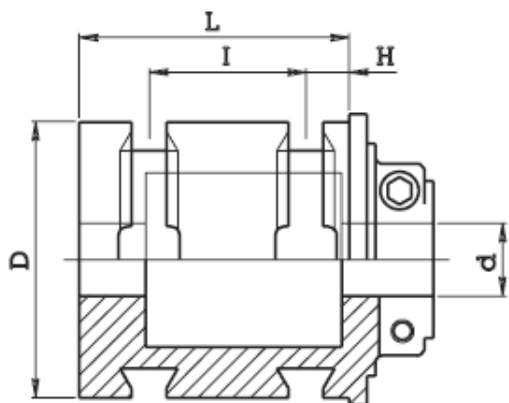

POZ. 1

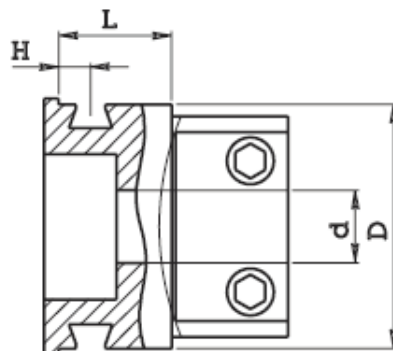

POZ. 2

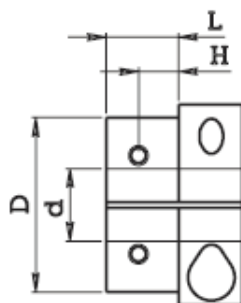

POZ. 3

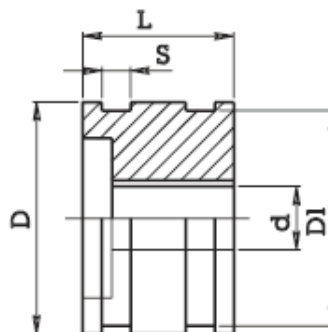

POZ. 4

## PRO VRTÁNÍ

KOD	D	d	L	H	I	Poz.	STROJ
502.001	110	30	132	12.5	100	1	TRAUB TD16-26-36
502.101	95	25	93	15	54	1	TRAUB A15-20-25
502.201	88	25	82	15	50	1	SAIC B26-30 A26-30-32 / ITS 26 / GIORGI 20-25-32
502.601	125	40	158	20	112	1	TRAUB A36-42-60 / SAIC B45 / ITS 36-42 (NB1)
502.701	125	35	158	20	112	1	TRAUB TB30-42-60

## PRO ZÁVITOŘEZ

KOD	D	d	L	H	Poz.	STROJ
502.101	95	25	93	15	1	TRAUB A15-20-25
504.201	84	25	39	11	2	SAIC B26-30 / ITS 26
504.202	88	25	39	15	2	ITS 26

## PRO PODÉLNÉ SOUSTRUŽENÍ

KOD	D	d	L	H	Poz.	STROJ	
506.101	60	25	25	10	3	TRAUB A15-20-25 / ITS 26 / GIORGI 20-25-32	
506.201	60	25	25	15	3	SAIC B26 / ITS 26 / GIORGI 20-25-32	
506.601	95	32	100	15	2	TRAUB A36-42-60	
506.701	125	35	158	20	1	TRAUB TB30-42-60	
500.001	VIZ PŘEDCHOZÍ STRANA						TRAUB TD16-26-36

## PRO OVLÁDÁNÍ KLEŠTINY

KOD	D	D1	d	S	L	Poz.	STROJ
508.001	115	110	30	54	73	4	TRAUB TD16-26-36
508.101	80	74	20	10	52	4	TRAUB A15-20-25
508.201	80	74	22	10	52	4	SAIC B26
508.601	120	110	28	15	72	4	TRAUB A36-42-60
508.701	140	130	30	15	92	4	TRAUB TB30-42-60

## KLÍNKY PRO UCHYCENÍ VAČEK

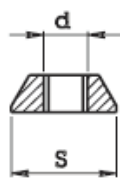

POZ. 1

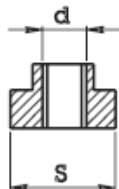
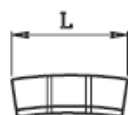

POZ. 2

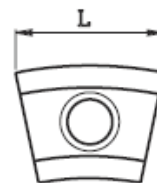
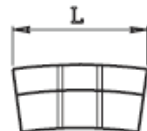

POZ. 3

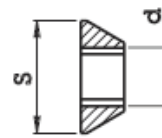

KOD	d	S	L	Poz.	STROJ	PRO VAČKY
510.101	6MA	18	19.5	1	TRAUB A1 5-20-25 TD 16-26-36	PODEPŘENÍ / ZÁVITOŘEZ
510.201	6MA	15	22	1	SAIC B26 / ITS 26	PODEPŘENÍ / ZÁVITOŘEZ
510.202	8MA	15.5	22	1	CASER TA26-30	PODEPŘENÍ / ZÁVITOŘEZ
510.203	8MA	16	29	2	ITS 36-42-60	PODEPŘENÍ / REVOLV.HLAVA
510.201	6MA	15	22	1	GIORGI 20-25-32	PODEPŘENÍ
510.207	6MA	19	20	1	GIORGI 20-25-32	ZÁVITOŘEZ
510.301	5MA	11.2	14	1	STROHM 75-105-125	TŘI VRTAČKY
510.302	6MA	11.2	14	1	STROHM 75-105-125	TŘI VRTAČKY
510.303	8MA	21	24	1	STROHM 205-255	TŘI VRTAČKY
510.304	6MA	11.5	15	3	STROHM 75-105-125	PŘÍČNÉ SUPORTY
510.601	8MA	20	23	1	TRAUB A36-42-60 TB30-42-60	PODEPŘENÍ / REVOLV.HLAVA

## PALCE

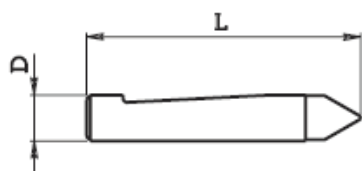

POZ. 1

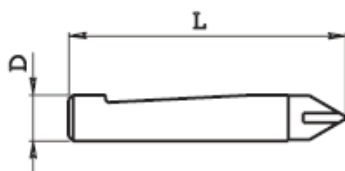

POZ. 2



POZ. 3

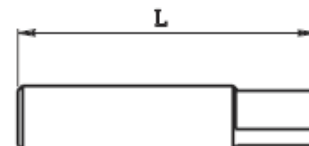

## POZ. 2: Palec s SK hrotem

KOD	D	L	Poz.	SUPPORT	STROJ
512.033	10	65	2	—	BECHLER AR 10
512.101	10	60	1	PŘÍČ - HORIZONT	TRAUB A1 5-20-25 TD16-26-36
512.101	10	60	1	PŘÍČ - HORIZONT	SAIC B26-30 / ITS 26 / GIORGI 25-32
512.105	12	55	3	PODELNE SOUSTR..	TRAUB A1 5-20-25 / SAIC B26-30 / ITS 26
512.110	10	60	2	PŘÍČ - HORIZONT	TRAUB A15-20-25 TD16-26-36 / SAIC B26-30 / ITS 26 / GIORGI 25-32
512.301	7	27	2	—	STROHM 125
512.601	12	75	1	PŘÍČ - HORIZONT	TRAUB A36-42-60 / SAIC B45 / ITS 36-42-60
512.601	12	75	1	PŘÍČ.	TRAUB TB 30-42-60
512.605	14	65	3	PODELNE SOUSTR..	TRAUB A36-42-60
512.610	12	75	2	PŘÍČ - HORIZONT	TRAUB A36-42-60 / SAIC B45 / ITS 36-42-60
512.610	12	75	2	PŘÍČ.	TRAUB TB30-42-60
512.701	16	64	1	HORIZONT.	TRAUB TB30-42-60

## ČEPY A ROLNY

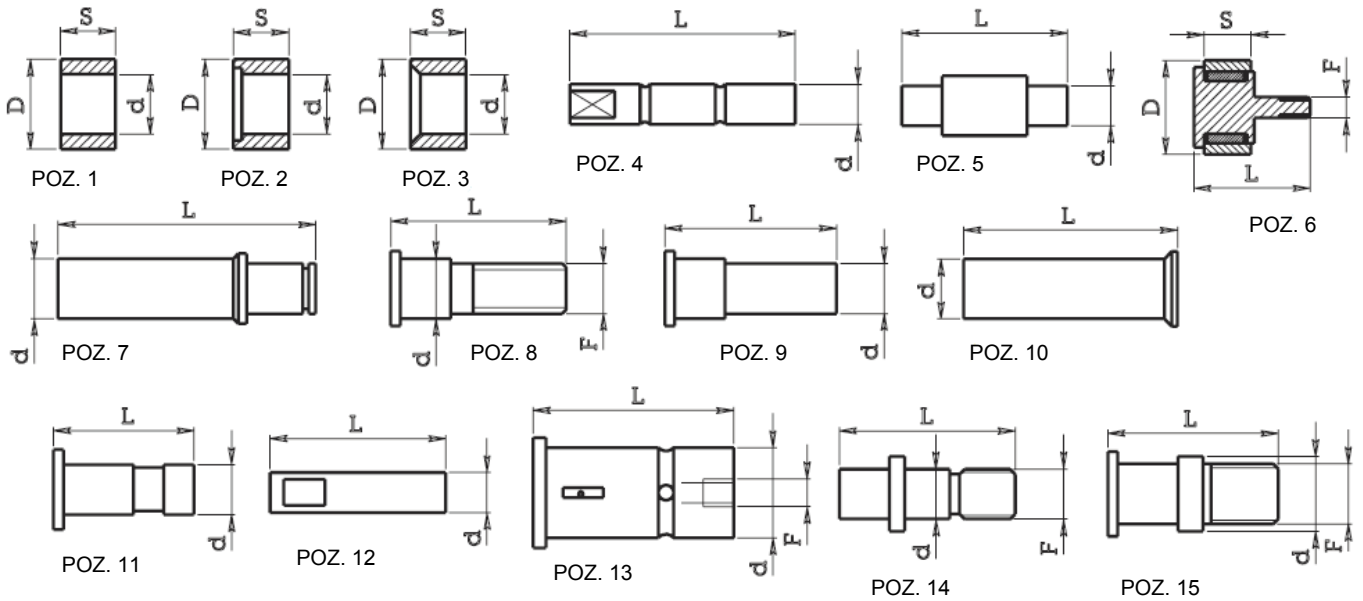

ČEP				ROLNA					KOD	STROJ	
KOD	d	L	F	Poz.	KOD	D	d	S	Poz.		KOMPL.
514.016	10	40	-	4	514.016B	17	10	14	1	-	ATA 25-40
514.531	6.35	33	-	12	514.532	12.8	6.35	9.2	1	-	BROWN e SHARPE
514.533	7	32	-	4	514.534	14	7	11.7	1	-	BROWN e SHARPE
514.535	8	30.5	-	4	514.536	14	8	11.7	1	-	BROWN e SHARPE
514.291	12	26	10x1	8	514.292	18	12	11	2	-	CASER 26-30
514.551	8	30	-	4	514.147B1	18	8	12	1	-	DAR 46
-	-	-	-	-	514.147B2	18	8	22	1	-	DAR 46
-	-	-	-	-	514.147B3	16	8	10	1	-	DAR 46
514.941	8	46	-	4	514.942	18	8	14	1	-	DAR 46
514.511	10	37.5	10	14	514.512	18	10	10	1	-	FEINLER 10-15
-	-	-	-	-	514.513	16	8	8	1	-	FEINLER 10-15
514.461A	8	32	-	12	514.462	20	8	10	1	-	GILDEMEISTER
514.461B	8	45	-	12	514.462	20	8	10	1	-	GILDEMEISTER
514.471	10	33	-	9	514.472	25	12	10	2	-	GILDEMEISTER
514.475	15	52	-	11	514.476	30	15	15	2	-	GILDEMEISTER
514.481	18	40	5	13	514.482	29.5	18	13	2	-	GILDEMEISTER
514.485	20	45	6	13	514.486	30	20	15	2	-	GILDEMEISTER
514.241	11	36	10	8	514.242	17	11	14	2	-	GIORGI 20-25-32
514.261	10	62	-	9	514.262	16	10.5	12	1	-	GIORGI 20-25-32
514.101	12	52	-	7	514.112	16	12	10	1	514.100	ITS 26
514.251	10	37	-	9	514.242	17	11	14	2	-	ITS 26
514.271	12	42	-	10	514.272	18	12	12	3	-	ITS 26
514.271	12	42	-	10	514.272	18	12	12	3	-	ITS 36-42-60
514.281	12	66	-	10	514.272	18	12	12	3	-	ITS 36-42-60
514.551	8	30	-	4	514.147B1	18	8	12	1	-	LOGOS 42-52
514.016	10	40	-	4	514.557B1	18	10	14	1	-	MAS 32-40-50
514.101	12	52	-	7	514.112	16	12	10	1	514.100	SAIC B26
514.231	12	31	10	8	514.232	18	12	10	2	-	SAIC B26-30
514.251	10	37	-	9	514.242	17	11	14	2	-	SAIC B26-30
514.471B	10/12	28	-	9	-	-	-	-	-	-	GILDEMEISTER
514.475B	15	40	-	11	514.476	30	15	15	2	-	GILDEMEISTER GM32/45
514.475C	15	55	-	11	514.476	30	15	15	2	-	GILDEMEISTER GM32/45

## ČEPY A ROLNY

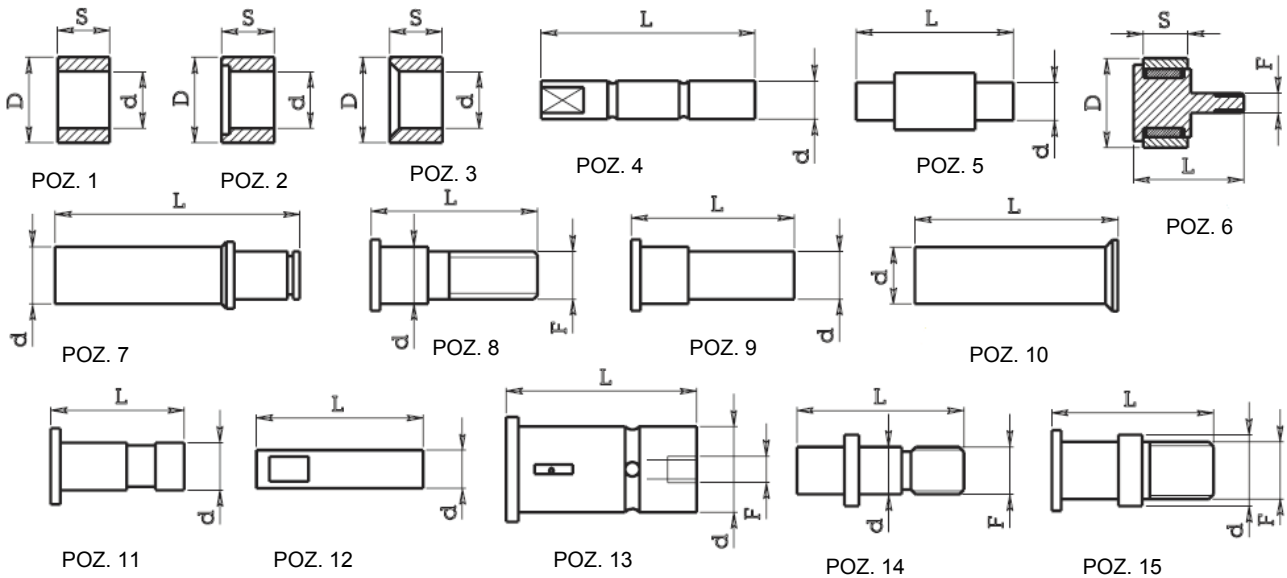

ČEP					ROLNA					KOD	STROJ	
KOD	d	L	F	Poz.	KOD	D	d	S	Poz.	jehly		COMPL.
514.211	12	23	8	8	514.212	18	12	12	2	-	-	SAIC A30
-	-	32	8	6	-	19	-	11	6	KR 19	514.220	SAIC A30
514.421	8	43	-	4	514.422	18	8	18	1	-	-	TAREX 42-52
514.101	12	52	-	7	514.112	16	12	10	1	-	514.100	TRAUB A15-20-25
514.111	12	23	10	8	514.112	16	12	10	1	-	-	TRAUB A15-20-25
514.121	12	36	10	8	514.112	16	12	10	1	-	-	TRAUB A15-20-25
514.711	12	23	10	15	514.112	16	12	10	1	1x8	514.710	TRAUB A15-20-25
514.011	10	28	-	11	514.012	20	10	8	1	-	-	TRAUB TD16-26-36
514.011	10	28	-	11	514.012B	20	13	8	1	1,5x8	514.010B	TRAUB TD16-26-36
514.021	8	33	-	5	Z714.010	12	8	10	1	BK 0810	-	TRAUB TD16-26-36
-	-	28	6x1	6	-	16	-	11	6	KR 16	514.030	TRAUB TD16-26-36
514.601	14	52	-	7	514.112	16	12	10	1	-	514.600	TRAUB A36-42-60
514.611	15	40	12	8	514.612	25	15	14	2	-	-	TRAUB A36-42-60
514.711	12	23	10	15	514.112	16	12	10	1	1x8	514.710	TRAUB TB30-42-60
514.721	15	34	12	15	514.722	22	15	11.7	2	1,5x12	514.720	TRAUB TB30-42-60
-	-	-	-	-	514.723	20	15	11.7	2	-	-	TRAUB TB30-42-60
514.021	8	33	-	5	Z714.010	12	8	10	1	BK 0810	-	TRAUB TB30-42-60
514.877A	11,5	32	-	9	514.877B	21	14,5	12	1	1,5x12	514.877	TRAUB CNC150
514.911	6	28	-	4	514.912	14	6	8	1	-	-	INDEX ON12-DG12
-	-	-	-	-	514.913	16	8	7.5	1	-	-	INDEX ON-OR12
514.921	6	37	-	4	514.922	14	6	12	1	-	-	INDEX 12-18-25
514.931	7	40	-	4	514.932	16	7	12	1	-	-	INDEX 24-C1 9-C29
514.941	8	46	-	4	514.942	18	8	14	1	-	-	INDEX 36-52
514.941	8	46	-	4	514.942	18	8	14	1	-	-	INDEX B30-42-60
514.980A	7	24	6x0,75	8	514.980B	12.8	9	8	1	-	514.980	INDEX12-18-25-C19
514.981A	6	22	6x0,75	8	514.981B	10.8	7	7	1	-	514.981	INDEX OR12-DG12
514.990A	9	32	8x1	8	514.990B	17.8	12	10	1	-	514.990	INDEX C29 24-36-52
514.990A	9	32	8x1	8	514.990B	17.8	12	10	1	-	514.990	INDEX C29 B30-42-60
514.111	12	23	10	8	514.112	16	12	10	1	-	-	SAIC A30
514.711	12	23	10	15	514.112	16	12	10	1	1x8	514.710	SAIC A30
514.811	18	45	14	8	514.812	25	18	14	2	-	-	SAIC B45