

VII - 1

# DRŽÁKY NÁSTROJŮ PRO CNC SOUSTRUHY

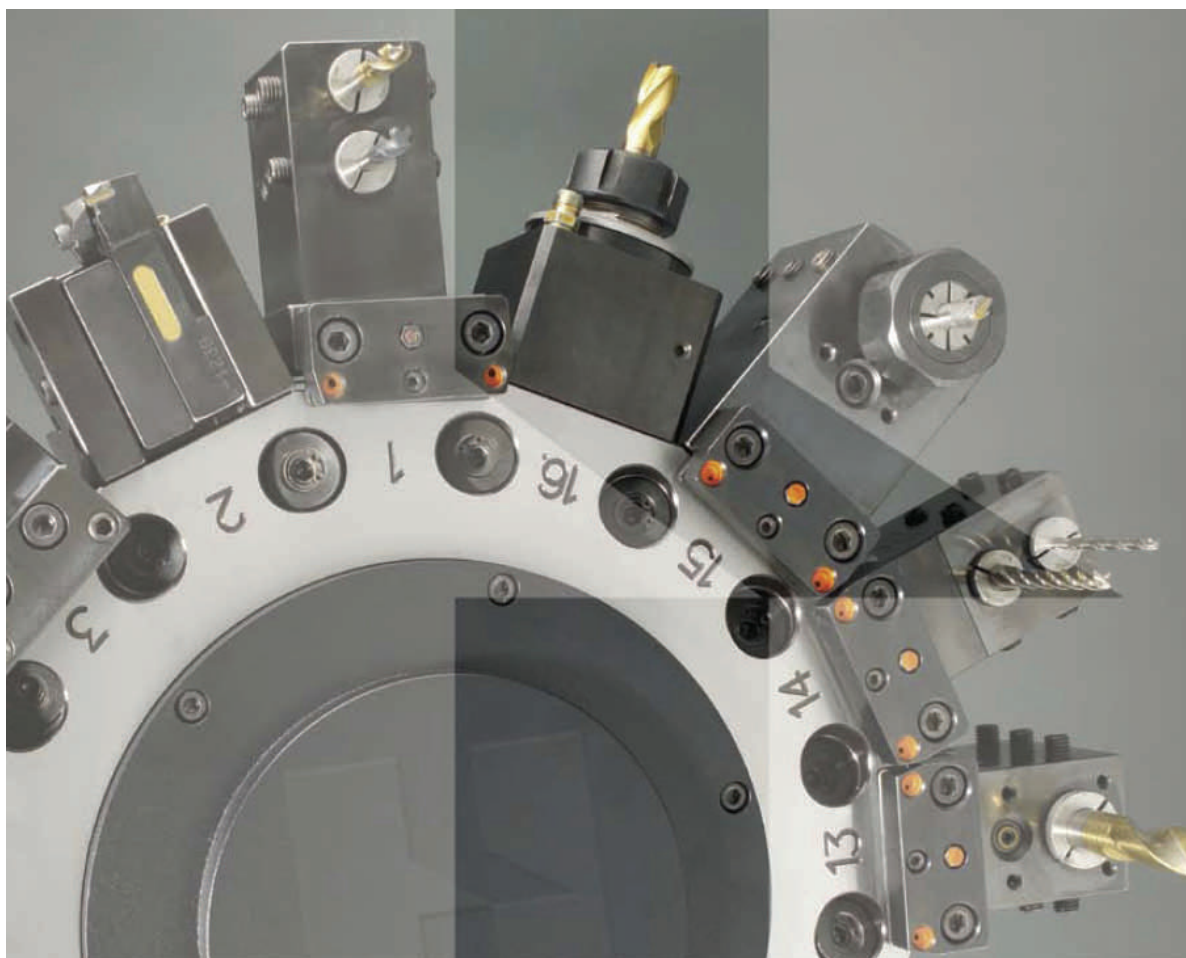

NTA s.r.o.  
Komenského 365  
763 16 Fryšták  
[www.nta.cz](http://www.nta.cz) [ntaoffice@nta.cz](mailto:ntaoffice@nta.cz)

**VII**



REV02-090114

## SOUSTRUH MORI SEIKI / NL / NT

## DRŽÁK AXIÁLNÍ

S VNITŘNÍM NEBO VNĚJŠÍM CHLAZENÍM

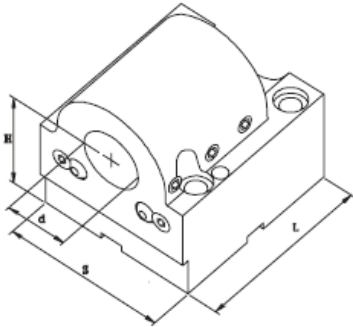

KOD	Kod Mori Seiki	d	H	S	L
7M8.C40	T10097	40	80	108	130
7M8.C40 R	T13128	40	80	108	130
7M8.C40 H120	T10113	40	120	108	130
7M8.C40 R H120	T13131	40	120	108	130
7M8.C50	T10098	50	80	108	130
7M8.C50 H120	T10114	50	120	108	130



Poz. 1

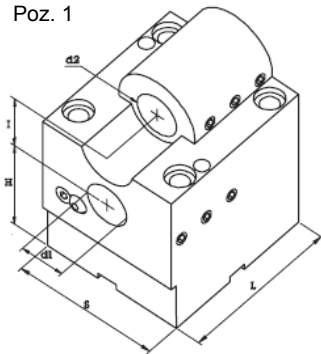

Poz. 2

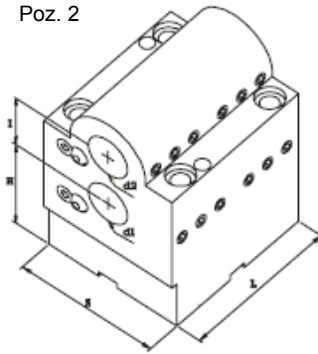

KOD	Kod Mori Seiki	d1-d2	H	I	S	L	Poz.
7M8.D32	T10096	32	80	45	108	130	1
7M8.D32 L	—	32	80	45	108	130	2

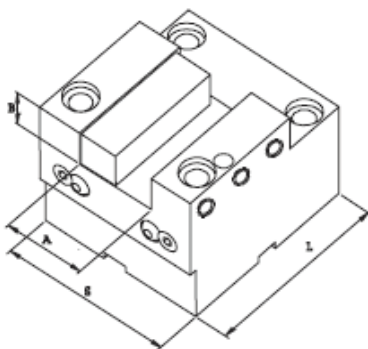

KOD	Kod Mori Seiki	A	B	S	L
8M8.C40	T03006	40	20	108	130
8M8.C50	T03005	50	25	108	130

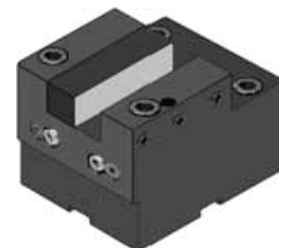

## ROZTEČE OTVORŮ

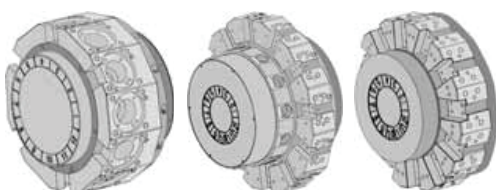
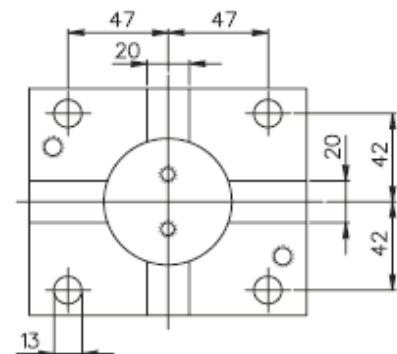

## SOUSTRUH MORI SEIKI / NL / NT

## DRŽÁK RADIÁLNÍ

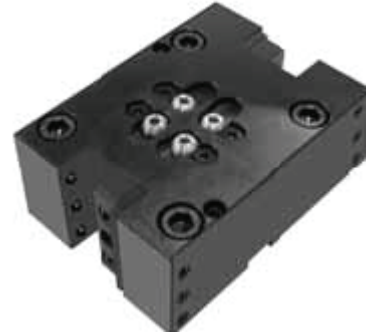
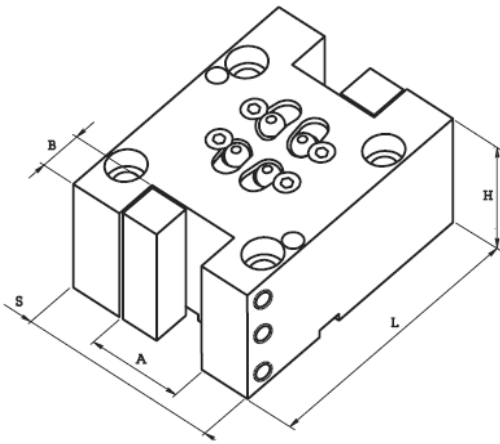

KOD	Kod Mori Seiki	A	B	S	L
8M8.D40	T00185	40	20	108	150
8M8.D50	T00184	50	25	108	160

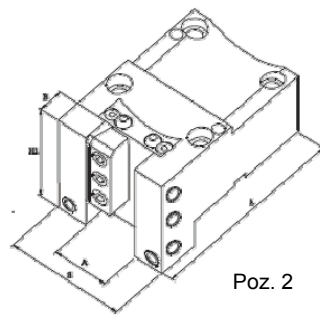
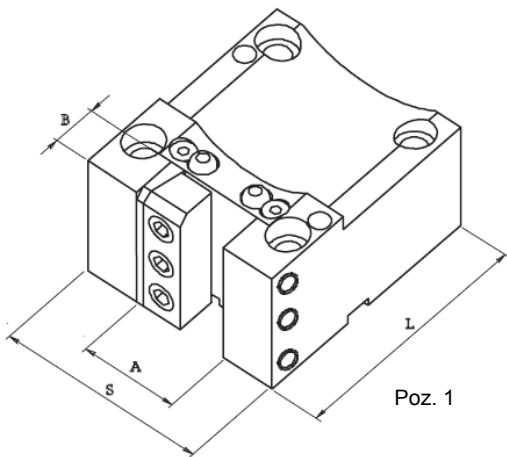

KOD	Kod Mori Seiki	A	B	S	L	H1	Poz.
8M8.V40	T00187	40	20	108	130	—	1
8M8.V50	T00186	50	25	108	130	—	1
8M8.V50 L	—	50	25	108	169	98	2

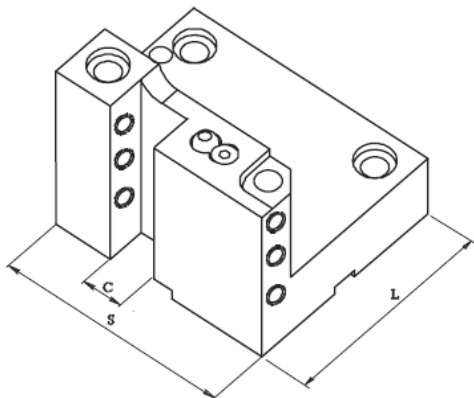

KOD	Kod Mori Seiki	C	S	L
8M8.B25	T00197	25	108	130

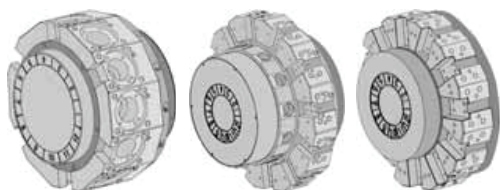

## ROZTEČE OTVORŮ

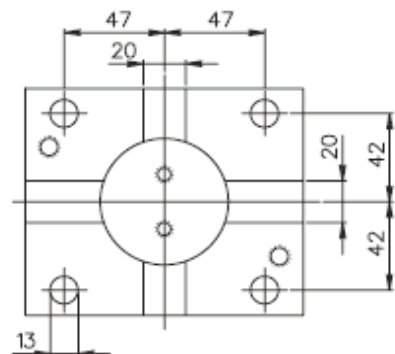

## SOUSTRUH MORI SEIKI / NZ / NL

## DRŽÁK AXIÁLNÍ

S VNITŘNÍM NEBO VNĚJŠÍM CHLAZENÍM

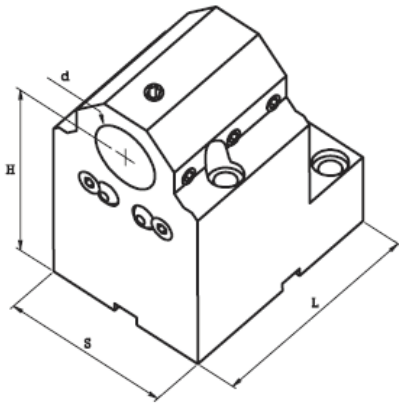

KOD	Kod Mori Seiki	d	H	S	L
7M5.C32	T10115	32	100	78	115
7M5.C32 R	T13132	32	100	78	115

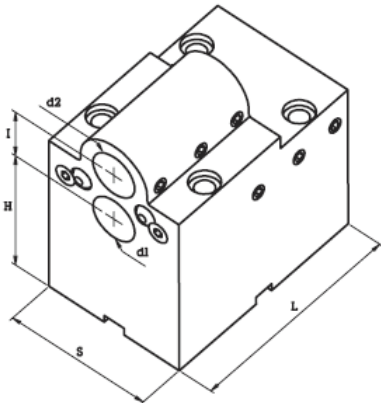

KOD	Kod Mori Seiki	d1-d2	H	I	S	L
7M5.D25	T10117	25	75	30	78	130

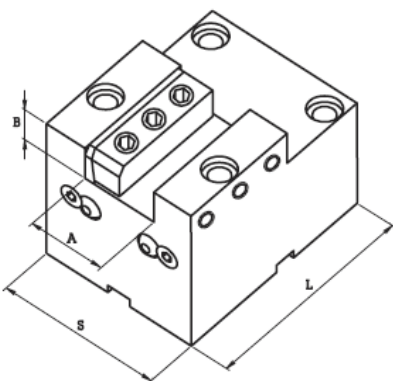

KOD	Kod Mori Seiki	A	B	S	L
8M5.C40	—	40	20	78	115

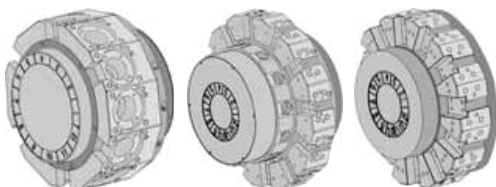

## ROZTEČE OTVORŮ

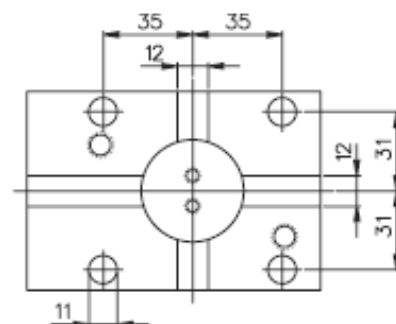

## SOUSTRUH MORI SEIKI / NZ / N

## DRŽÁK RADIÁLNÍ

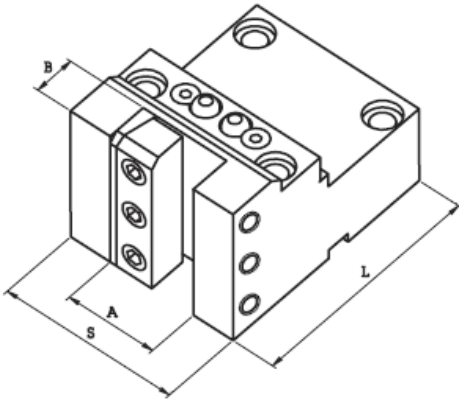

KOD	Kod Mori Seiki	A	B	S	L
8M5.V40	T00224	40	20	78	115

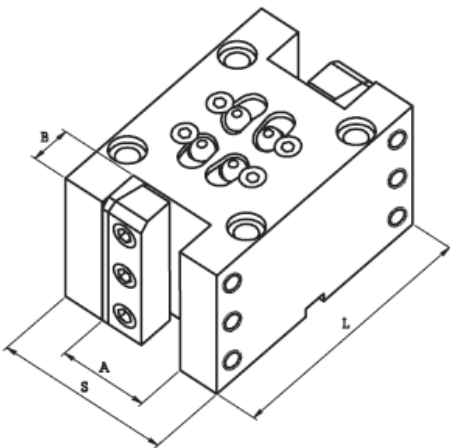

KOD	Kod Mori Seiki	A	B	S	L
8M5.D40	T00228	40	20	78	130

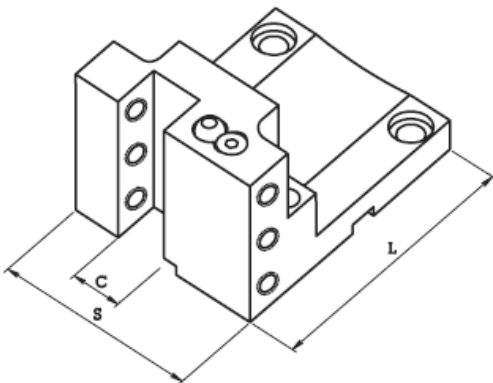

KOD	Kod Mori Seiki	C	S	L
8M5.B20	T00251	20	78	115

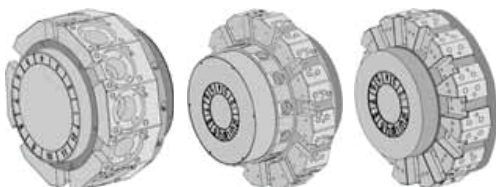

## ROZTEČE OTVORŮ

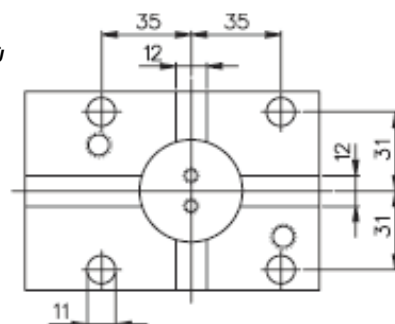

## SOUSTRUH MORI SEIKI / SL / CL / ZL ● DURA TURN ● CMZ ● GOODWAY

## DRŽÁK AXIÁLNÍ

S VNITŘNÍM NEBO VNĚJŠÍM CHLAZENÍM

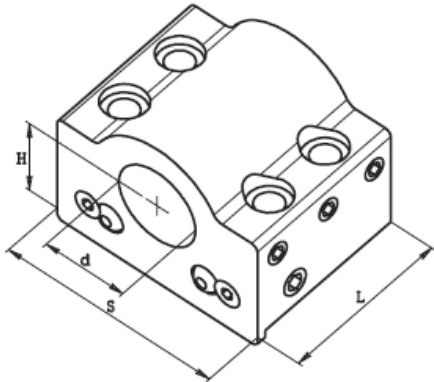

KOD	Kod Mori Seiki	d	H	S	L	Poz.
7M3.C32	T10046	32	35	90	79	1
7M3.C32 R	T13066	32	35	90	79	1
7M6.C40	T10036	40	40	105	90	2
7M6.C40 R	T13064	40	40	105	90	2
7M6.C50	T10044	50	40	105	90	2

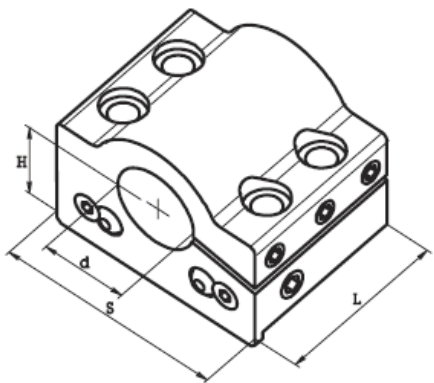

KOD	Kod Mori Seiki	d	H	S	L	Poz.
7M6.C25 B	—	25	40	105	90	2
7M6.C40 B	T10036	40	40	105	90	2
7M6.C50 B	T10044	50	40	105	90	2

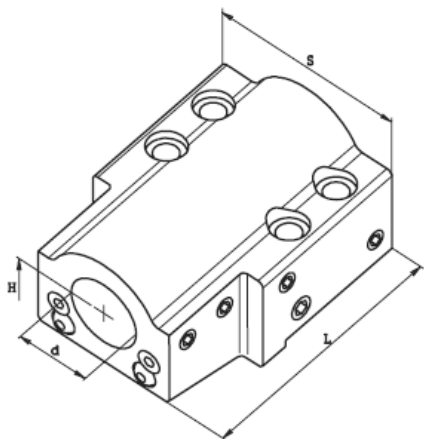

KOD	Kod Mori Seiki	d	H	S	L	Poz.
7M3.L32	T10052	32	35	90	139	1
7M6.L40	T10038	40	40	105	160	2
7M6.L50	T10094	50	40	105	160	2

## ROZTEČE OTVORŮ

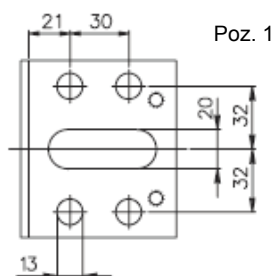
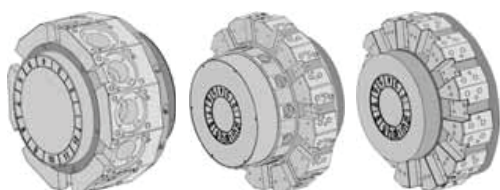

Poz. 1

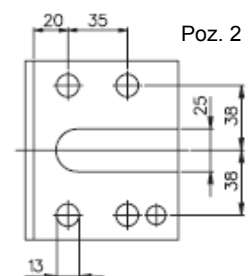

Poz. 2

## DRŽÁKY PRO CNC SOUSTRUHY

## SOUSTRUH MORI SEIKI / SL / CL / ZL ● DURA TURN ● CMZ ● GOODWAY

## DRŽÁK AXIÁLNÍ

S VNITŘNÍM NEBO VNĚJŠÍM CHLAZENÍM

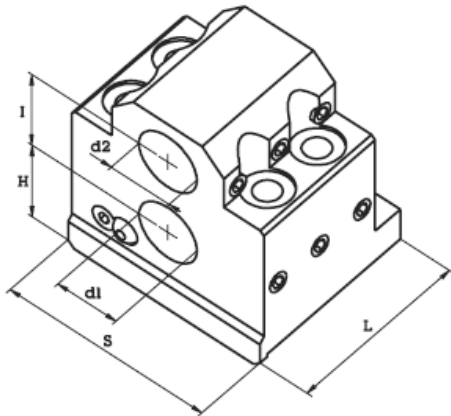

KOD	Kod Mori Seiki	d1-d2	H	I	S	L	Poz. 1
7M3.D25	T10082	25	35	40	90	79	1
7M6.D32	T10086	32	40	45	105	90	2
7M6.D32 L	T10208	32	40	45	105	125	2

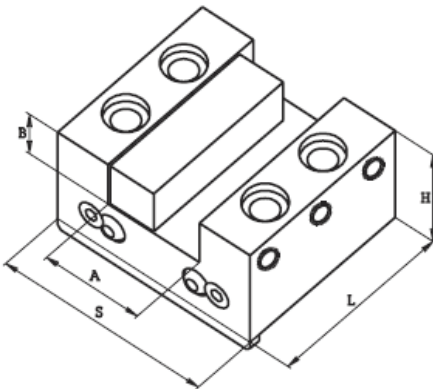

KOD	Kod Mori Seiki	A	B	S	L	H	Poz.
8M3.C40	T00080	40	20	90	79	45	1
8M6.C50	T00068	50	25	106	90	55	2

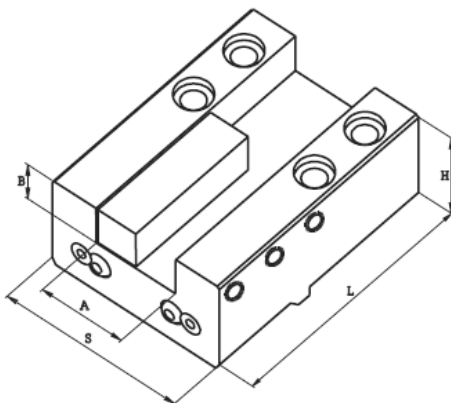

KOD	Kod Mori Seiki	A	B	S	L	H	Poz.
8M3.L40	T00148	40	20	90	139	50	1
8M6.L50	T00082	50	25	106	160	60	2

## ROZTEČE OTVORŮ

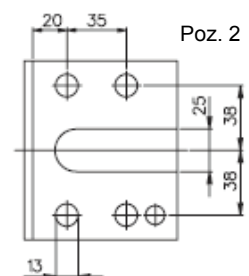
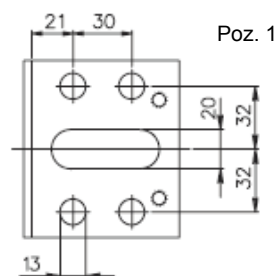
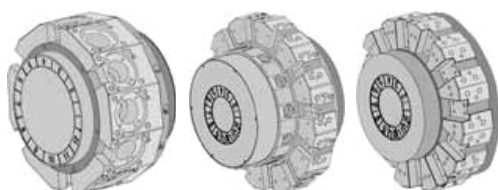

## DRŽÁK RADIÁLNÍ

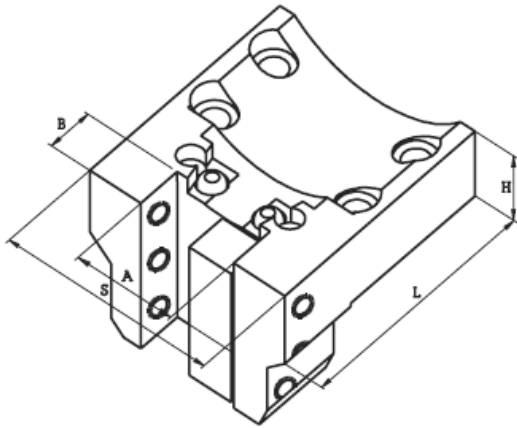

KOD	Kod Mori Seiki	A	B	S	L	H	Poz.
8M3.V40	T00146	40	20	90	115	35	1
8M6.V50	T00074	50	25	106	130	40	2
8M6.V50 L	T00076	50	25	106	155	40	2

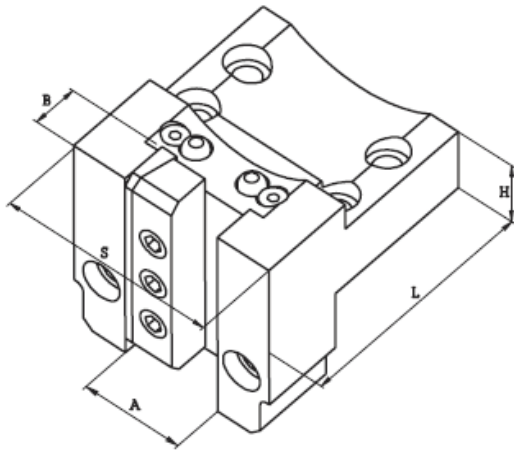

KOD	Kod Mori Seiki	A	B	S	L	H	Poz.
8M3.T40	T00078	40	20	90	115	45	1
8M6.T50	T00162	50	25	106	130	35	2
8M6.T50 L	T00164	50	25	106	160	35	2

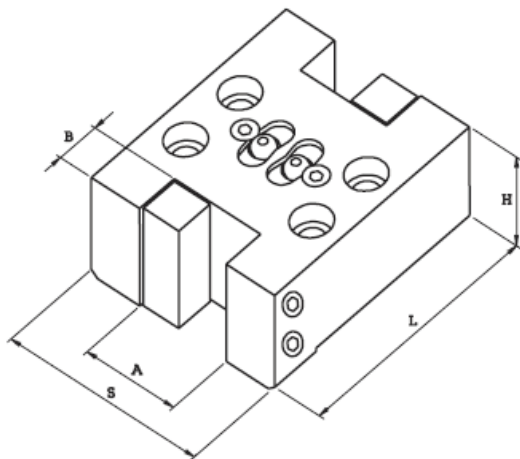

KOD	Kod Mori Seiki	A	B	S	L	H	Poz.
8M3.D40	T00108	40	20	90	120	50	1
8M6.D50	T00158	50	25	106	141	60	2

## ROZTEČE OTVORŮ

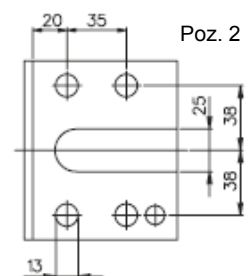
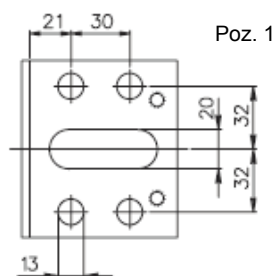
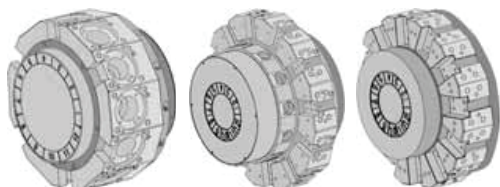

## DRŽÁKY PRO CNC SOUSTRUHY

## SOUSTRUH MORI SEIKI / SL / CL / ZL ● DURA TURN ● CMZ ● GOODWAY

## DRŽÁK RADIÁLNÍ

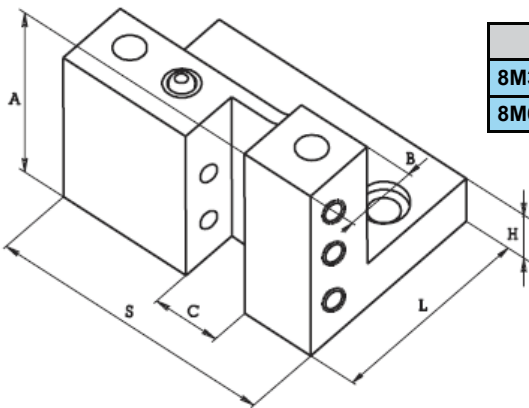

KOD	Kod Mori Seiki	A	B	C	S	L	H	Úpich	Poz.
8M3.B20	T00134	68	31	20	90	75	21	Pravý	1
8M6.B25	T00156	78	31	25	106	85	21	Pravý	2

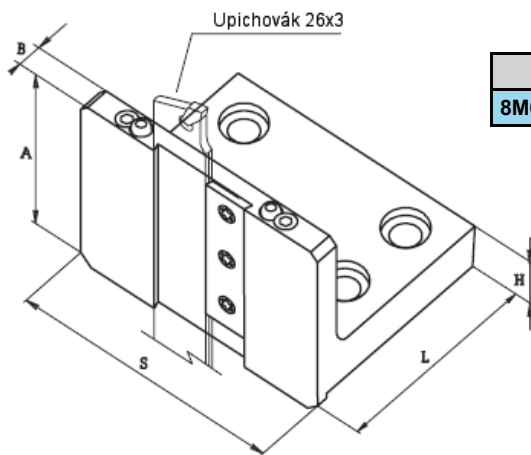

KOD	Kod Mori Seiki	A	B	C	S	L	H	Úpich	Poz.
8M6.B26	—	75	11	—	106	90	21	Pr-lev	2

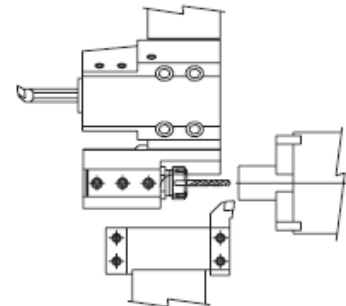
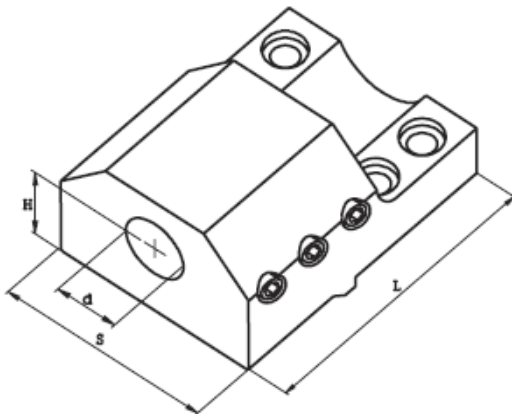

KOD	Kod Mori Seiki	d	H	S	L	Poz.
7M3.S25	—	25	35	90	139	1
7M3.S32 H50	—	32	50	90	79	1
7M6.S32	—	32	40	105	160	2

## S VNITŘNÍM NEBO VNĚJŠÍM CHLAZENÍM

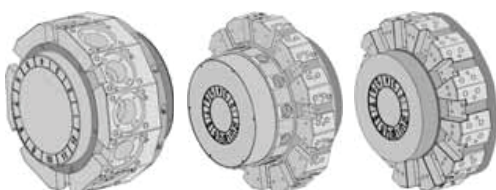

## ROZTEČE OTVORŮ

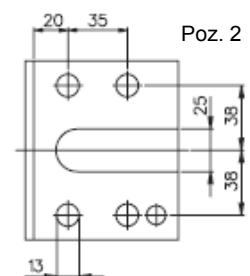
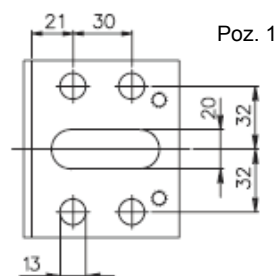

## SOUSTRUH HAAS

## DRŽÁK AXIÁLNÍ

S VNITŘNÍM NEBO VNĚJŠÍM CHLAZENÍM

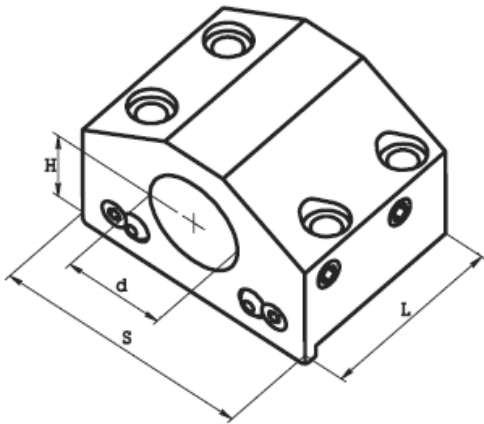

KOD	Kod HAAS	d	H	S	L
7H6.C32	BOT20MID	32	31.75	101.5	82.5
7H6.C40	BOT20MID	40	31.75	101.5	82.5

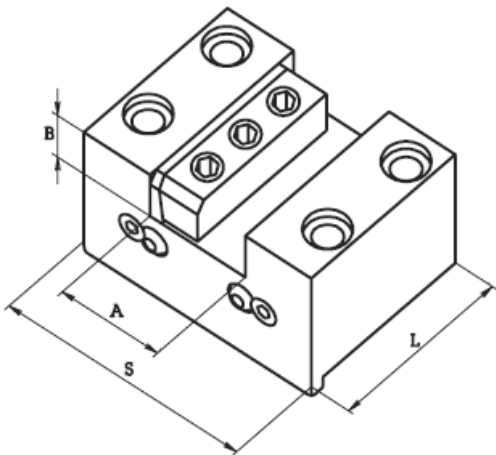

KOD	Kod HAAS	A	B	S	L
8H6.C50	BOT20MFG	50	25	101.5	82.5

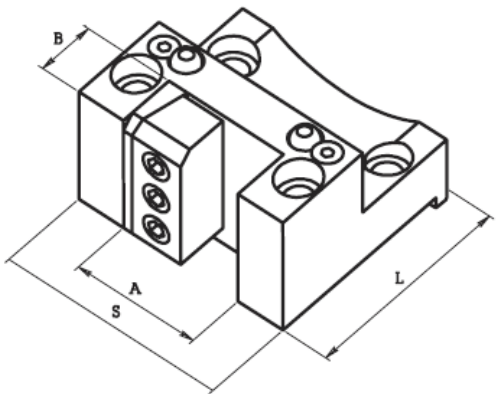

KOD	Kod HAAS	A	B	S	L
8H6.V50	BOT20MOD	50	25	101.5	92

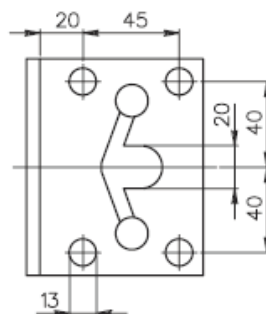
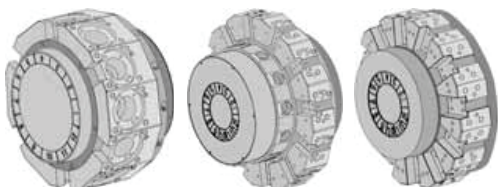

ROZTEČE OTVORŮ

## DRŽÁKY PRO CNC SOUSTRUHY

## SOUSTRUH GOODWAY

## DRŽÁK AXIÁLNÍ

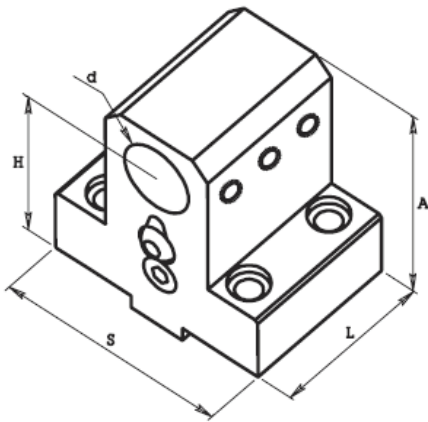

S VNITŘNÍM NEBO VNĚJŠÍM CHLAZENÍM

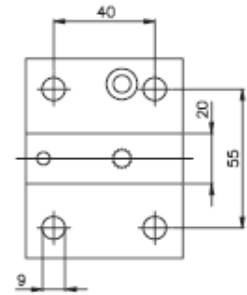

KOD	STROJ	d	H	S	L	A
7G3.C25 60	GLS200	25	60.2	79	62	78.7
7G3.C32 60	GLS200MC	32	60.2	79	62	82.7

## DRŽÁK RADIÁLNÍ

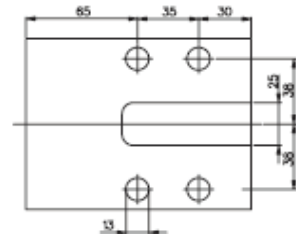
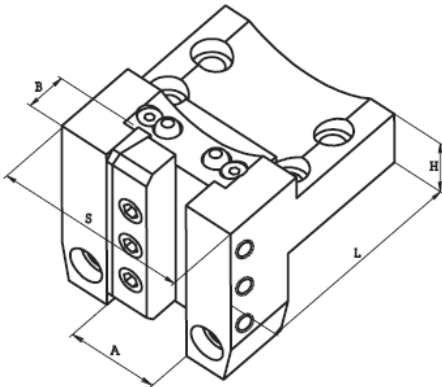

KOD	STROJ	A	B	S	L	H
8G6.T50	—	50	25	100	130	40

## SOUSTRUH GOODWAY - MURATA - TONG TAI TNL 150

## DRŽÁK AXIÁLNÍ

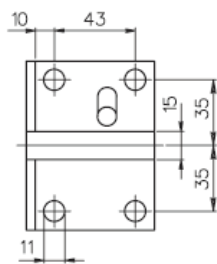
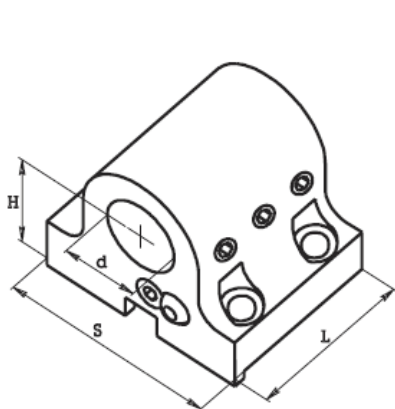

Poz.1

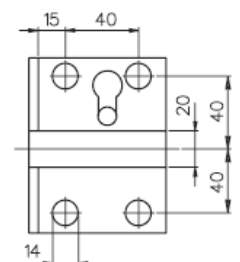
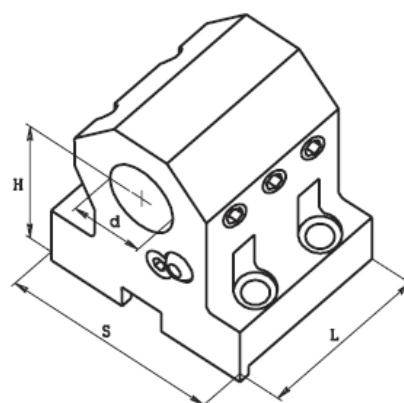

Poz.2

S VNITŘNÍM NEBO VNĚJŠÍM CHLAZENÍM

KOD	d	H	S	L	Poz.
7T3.C32	32	45	90	68	1
7T5.C32	32	65	96	75	2
7T5.C40	40	65	96	75	2