

IV - 1

DRŽÁKY NÁSTROJŮ PRO AUTOMATY

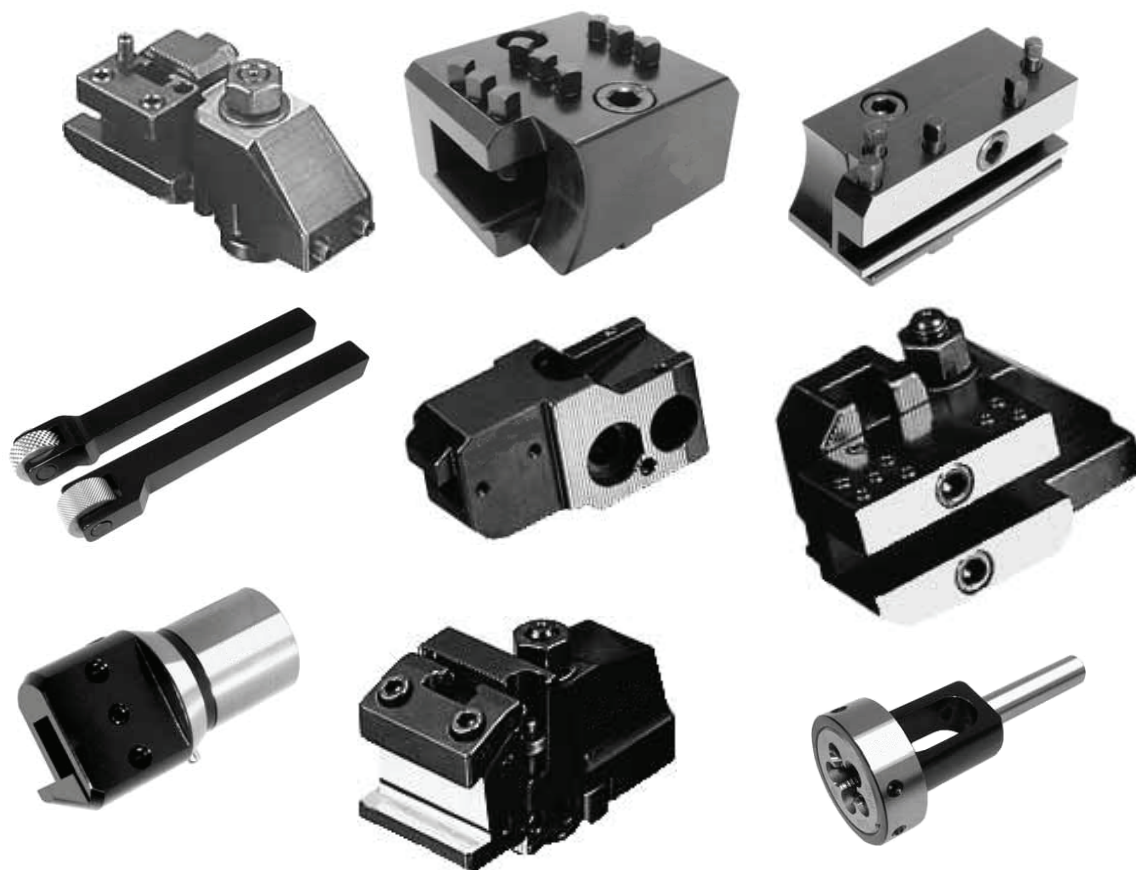

NTA s.r.o.
Komenského 365
763 16 Fryšták
www.nta.cz ntaoffice@nta.cz



IV

REV02-090129

DRŽÁK PLOCHÉHO NOŽE PRO PŘÍČNÝ SUPORT

TENTO DRŽÁK LZE POUŽÍT PRO PŘEDNÍ I ZADNÍ SUPORT

INDEX 12-18-25 TRAUB TD 16-26-36 ATA 25

KOD	A	H min	H max	C	D	S
	50	16	32	10	10	10
260.200	n° 0 - Držák kompletní					
260.201	n° 1 - Základna					
260.202	n° 2 - Držák nože					
260.203	n° 3 - Šroub					
260.204	n° 4 - Šroub					
260.205	n° 5 - Příložka					

INDEX C19 - 29

KOD	A	H min	H max	C	D	S
	54	19	42	14	14	12
260.300	n° 0 - Držák kompletní					
260.301	n° 1 - Základna					
260.402	n° 2 - Držák nože					
260.303	n° 3 - Šroub					
260.404	n° 4 - Šroub					
260.405	n° 5 - Příložka					

INDEX 36-42-52-60 TRAUB TB 42-60 ATA 40 SKODA 40 TAREX 42

KOD	A	H min	H max	C	D	S
	60	19	42	14	14	14
260.400	n° 0 - Držák kompletní					
260.401	n° 1 - Základna					
260.402	n° 2 - Držák nože					
260.403	n° 3 - Šroub					
260.404	n° 4 - Šroub					
260.405	n° 5 - Příložka					

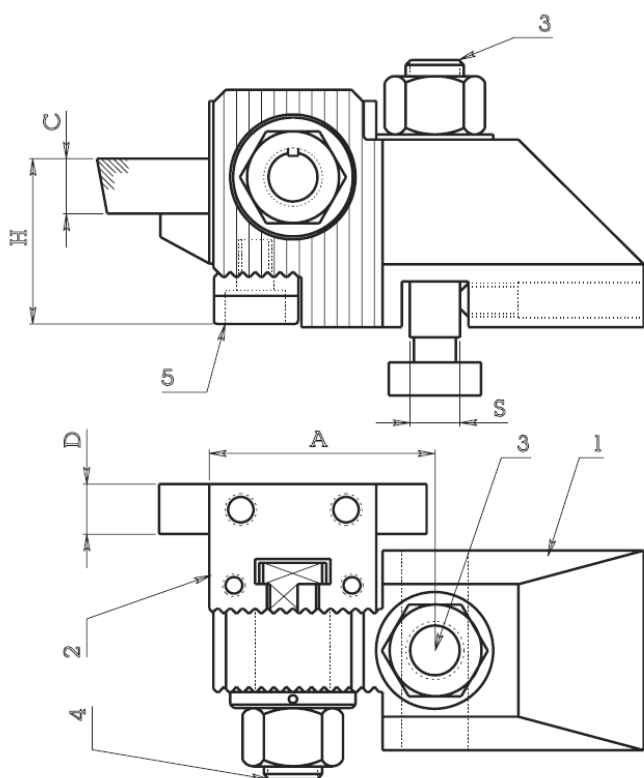

DRŽÁK PLOCHÉHO NOŽE

KOD	C	D	L	S	Pro nůž	Poz.
260.202	10,5	10	48	22,5	10x10	1
260.202B	10,5	20,5	48	37,5	10x20	2
260.402	15	13	64	30	12x12	1
260.402B	15	25,5	64	47,5	12x20	2
260.402C	15	30,5	64	52,5	16x32	2

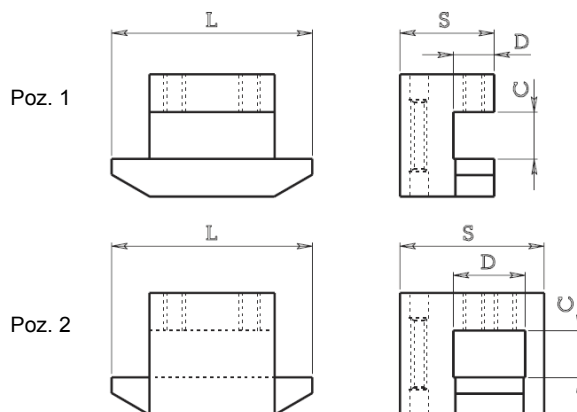

DRŽÁK PLOCHÉHO NOŽE PRO DVOJITÝ PŘÍČNÝ SUPORT

INDEX 12-18-25 TRAUB TD 16-26-36 ATA 25

KOD zadní	A	H min	H max	C	D	S	KOD přední
	58	15	32	13	18	10	
270.210	n° 0 - Držák kompletní						270.200
270.211	n° 1 - Základna						270.201
270.212	n° 2 - Držák nože						270.202
270.203	n° 3 - Šroub						270.203
270.205	n° 5 - Příložka						270.205



INDEX 36-42-52-60 TRAUB TB 42-60 ATA 40 ŠKODA 40 TAREX 42

KOD zadní	A	H min	H max	C	D	S	KOD přední
	73	17	42	15.3	25	14	
270.410	n° 0 - Držák kompletní						270.400
270.411	n° 1 - Základna						270.401
270.412	n° 2 - Držák nože						270.402
260.403	n° 3 - Šroub						260.403
270.405	n° 5 - Příložka						270.405

VOYBRAZENÝ DRŽÁK JE PRO PŘEDNÍ SUPORT

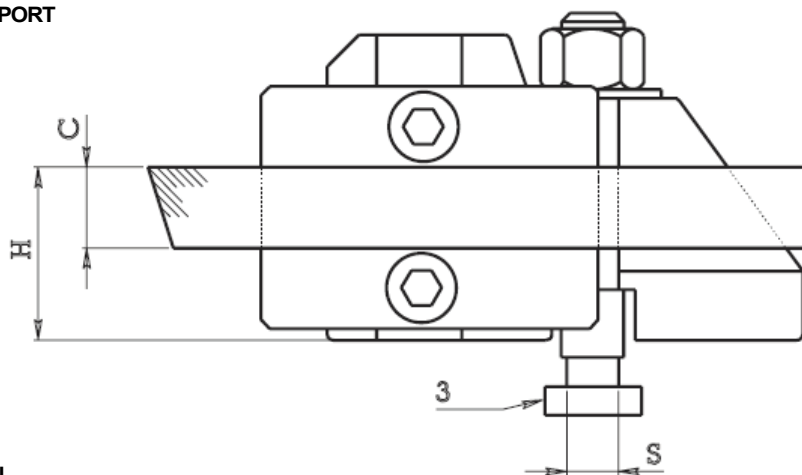

UPEVNĚNÍ TĚCHTO DRŽÁKŮ NA SAMOTNÝ STROJ JE ODVISLÉ OD TYPU STROJE, NA KTERÝ JE DRŽÁK MONTOVÁN. DALŠÍ INFORMACE NALEZNETE NA STRANĚ 4, KDE JE SPECIFIKOVÁNA KOMPATIBILITA UCHYCENÍ DLE TYPU STROJŮ.

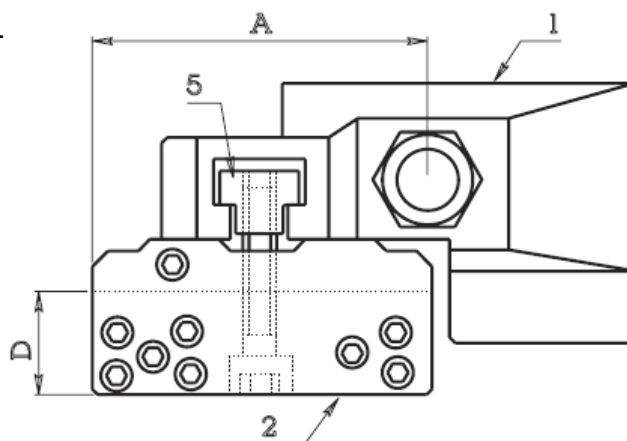

DRŽÁK PRIZMATICKÉHO NOŽE PRO PŘÍČNÝ SUPORT

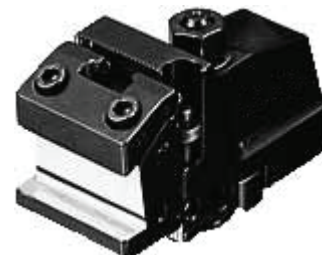
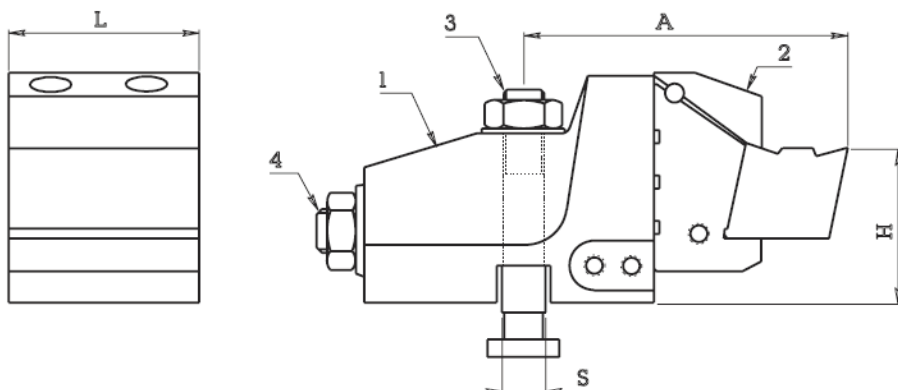

INDEX 12-18-25

INDEX 36-42-52-60

KOD	A	L	H	S
	73	46	30	10
280.200	n° 0 - Držák kompletní			
280.201	n° 1 - Základna			
280.202	n° 2 - Držák nože			
280.203	n° 3 - Šroub			
280.204	n° 4 - Šroub			

KOD	A	L	H	S
	83	50	36	14
280.400	n° 0 - Držák kompletní			
280.401	n° 1 - Základna			
280.402	n° 2 - Držák nože			
260.403	n° 3 - Šroub			
280.404	n° 4 - Šroub			

UCHYCENÍ DRŽÁKŮ NA STROJ - ŠROUBY

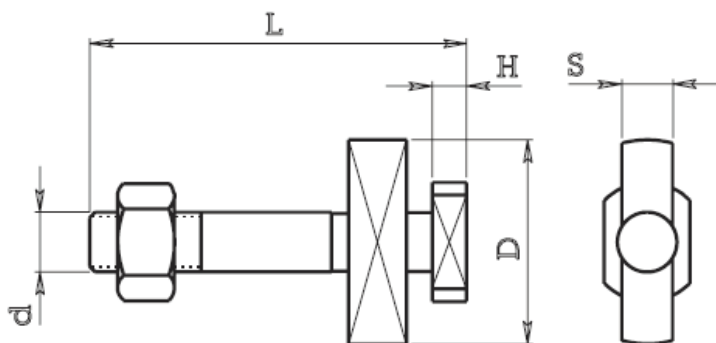

KOD	S	d	L	H	D	STROJ
260.203	10	10	59	5	29	INDEX 12-18-25 TRAUB TD16-26-36
260.203B	12	10	59	5	29	INDEX C 19-29 TRAUB A 15-20-25

KOD	S	d	L	H	D	STROJ
260.303	12	14	74	8	48	INDEX C19-29
260.403	14	14	88	8	48	INDEX 36-52-60
260.403B	15	14	88	8	48	TRAUB TB 42-60
260.403C	16	14	88	8	48	ATA 40 SKODA 40
260.403D	12	14	88	8	48	INDEX C 19-29
270.203	10	10	67	5	40	INDEX 12-18-25
270.203B	12	10	67	5	40	INDEX C 19-29
280.203	10	10	67	5	48	INDEX 12-18-25
280.203B	12	10	67	5	48	INDEX C 19-29

UPÍNACÍ ŠROUBY

KOD	d	D	L	H	Pro držák	Poz.
280.204	M10	20	97	6	280.200	1
280.404	M14	25	122	7	280.400	1
260.204	M10	14	37	4	260.200	2
260.404	M14	18	47	5.5	260.400 260.300	2

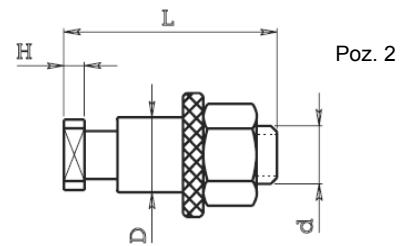
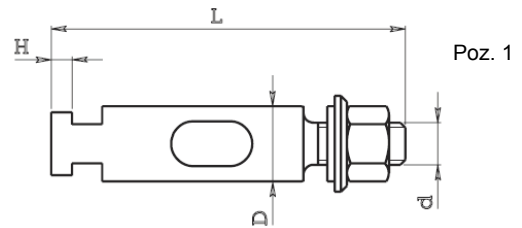

PŘÍLOŽKA

KOD	L	S	H	Pro držák
260.205	30	22	13	260.200
260.405	40	20	18	260.300 260.400

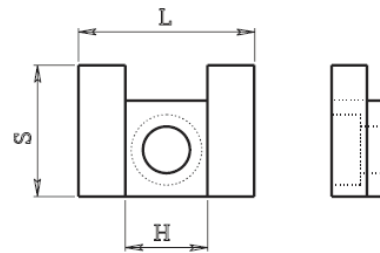

DRŽÁK NOŽE

INDEX E-ER 42-52-60								
KOD	A	B	d	D	H	L	S	Poz.
288.110	10	10	32	41	40	80	18	1
288.114	14	14	32	41	40	80	19	1
288.116	16	16	32	41	40	80	25	1
288.120	20	16	32	41	40	80	28	1
288.140	42	12	32	52	42	82	40	2

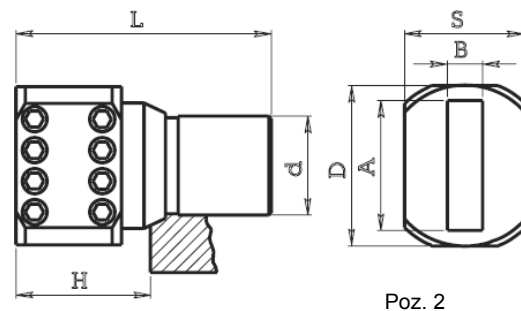
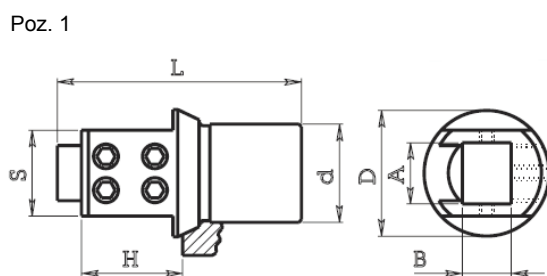

DRŽÁK UPICHOVACÍHO NOŽE PRO INDEX E-ER 42-60

KOD	B	d	H	L	S	Poz.
288.317D	17	32	42	82	22	1 (PRAVÝ)
288.317S	17	32	42	82	22	2 (LEVÝ)

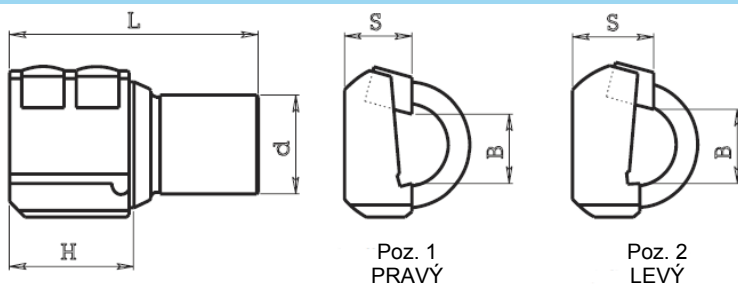

POLOTOVARY UPICHOVACÍCH NOŽŮ			
KOD	S	H	B
BT 1703	3	2	17
BT 1704	4	3	17
BT 1705	5	4	17
BT 1706	6	5	17

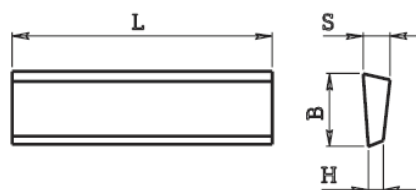

DRŽÁK UPICHOVACÍHO NOŽE PRO INDEX E-ER 42-60

KOD	B	d	H	L	S
288.325	26	32	42	82	22

Tento držák lze použít jako pravý nebo levý

UPICHOVACÍ NOŽE							
TĚLO						PLÁTEK	
KOD	H	S	L	h	D	KOD	W
PL 2616	26	1.6	110	21,4	50	PL 22 IN	2,2
PL 2616	26	1.6	110	21,4	50	PL 24 IN	2,4
PL 2624	26	2.4	110	21,4	75	PL 31 IN	3,1
PL 2632	26	3.2	110	21,4	80	PL 41 IN	4,1

D = Max. průměr úpichu

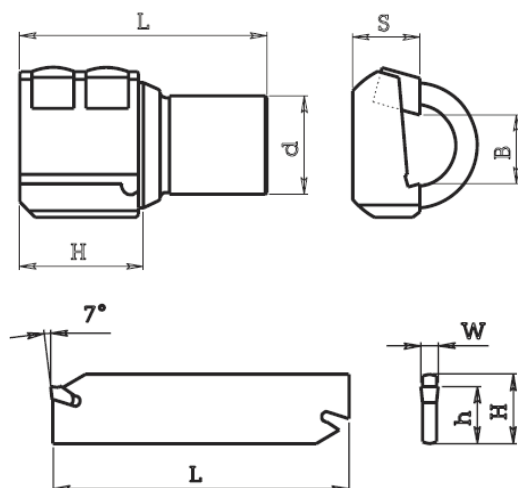

DRŽÁK PRISMATICKÉHO NOŽE PRO INDEX E-ER 42-60

KOD	B	d	D	H	L	S
288.400	25	32	60	50	90	42

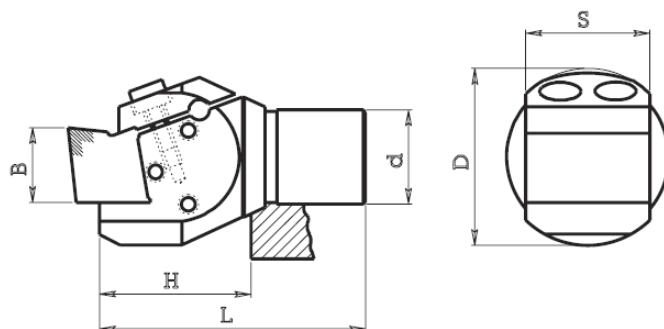

DRŽÁK NOŽE PRO SVISLÝ SUPORT

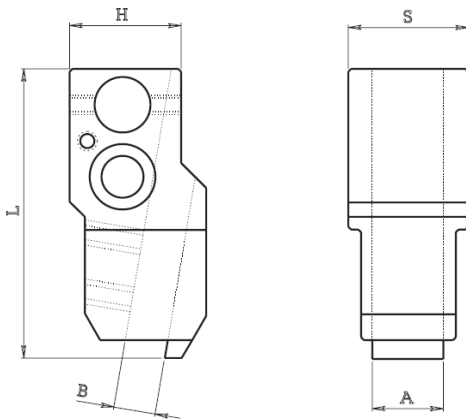

KOD	A	B	S	H	L	STROJ
290.204	4	11	20	35	82	INDEX 12-18-25
290.210	10	11	26	35	82	INDEX 12-18-25
290.220	20	21	36	35	82	INDEX 12-18-25
290.406	6	18	25	50	105	INDEX C19-29 B42-60
290.412	12	15	30	50	105	INDEX C19-29 B42-60
290.414	14	15	32	50	105	INDEX C19-29 B42-60
290.420	20	15	37	50	105	INDEX C19-29 B42-60
290.425	25	15	43	50	105	INDEX C19-29 B42-60

DISTANČNÍ DESKA POD DRŽÁK 290.XXX

KOD	S	H	L	Pro držák
291.205	5	30	52	290.200
291.210	10	30	52	290.200
291.215	15	30	52	290.200
291.220	20	30	52	290.200
291.405	5	40	61	290.400
291.410	10	40	61	290.400
291.415	15	40	61	290.400
291.420	20	40	61	290.400

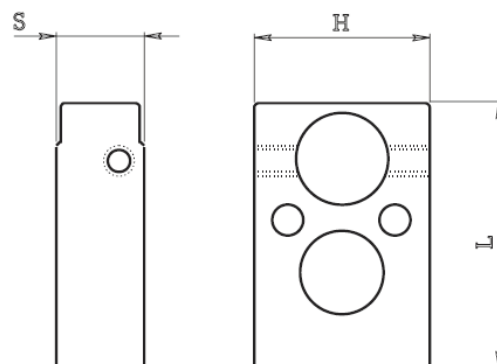

DRŽÁK PLOCHÉHO NOŽE NAKLÁPĚCÍ PRO PŘÍČNÝ SUPORT

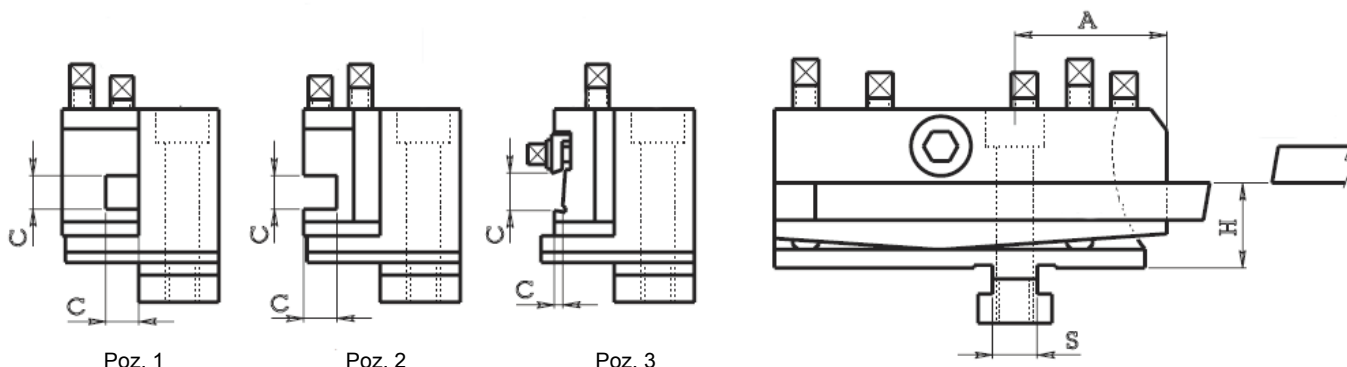

Poz. 1

KOD	poloha	H	A	S	C	Kod těleso	Kod držáku	STROJ
300.101	SPODNÍ	22	41	12	10x10	300.101 A	300.101 B	TRAUB A 15-20-25 / SAIC B26 / ITS 26
300.201	HORNÍ	22	41	12	10x10	300.201 A	300.201 B	TRAUB A 15-20-25 / SAIC B26 / ITS 26
300.601	SPODNÍ	40	62	15	12x12	300.601 A	300.601 B	TRAUB A 36-42-60 TB 42-60 / SAIC B45 / ITS 60
300.701	HORNÍ	40	62	15	12x12	300.701 A	300.701 B	TRAUB A 36-42-60 TB 42-60 / SAIC B45 / ITS 60

Poz. 2

KOD	poloha	H	A	S	C	Kod těleso	Kod držáku	STROJ
302.101	SPODNÍ	22	41	12	10x10	300.101 A	302.101 B	TRAUB A 15-20-25 / SAIC B26 / ITS 26
302.102	SPODNÍ	22	41	12	10x20	300.101 A	302.102 B	TRAUB A 15-20-25 / SAIC B26 / ITS 26
302.201	HORNÍ	22	41	12	10x10	300.201 A	302.201 B	TRAUB A 15-20-25 / SAIC B26 / ITS 26
302.202	HORNÍ	22	41	12	10x20	300.201 A	302.202 B	TRAUB A 15-20-25 / SAIC B26 / ITS 26
302.601	SPODNÍ	40	62	15	12x12	300.601 A	302.601 B	TRAUB A 36-42-60 TB 42-60 / SAIC B45 / ITS 60
302.602	SPODNÍ	40	62	15	12x25	300.601 A	302.602 B	TRAUB A 36-42-60 TB 42-60 / SAIC B45 / ITS 60
302.701	HORNÍ	40	62	15	12x12	300.701 A	302.701 B	TRAUB A 36-42-60 TB 42-60 / SAIC B45 / ITS 60
302.702	HORNÍ	40	62	15	12x25	300.701 A	302.702 B	TRAUB A 36-42-60 TB 42-60 / SAIC B45 / ITS 60
302.141	SPODNÍ	26	40	12	10x10	300.141 A	302.141 B	GIORGI GM 20-32
302.142	SPODNÍ	26	40	12	10x25	300.141 A	302.142 B	GIORGI GM 20-32
302.241	HORNÍ	26	40	12	10x10	300.241 A	302.241 B	GIORGI GM 20-32
302.242	HORNÍ	26	40	12	10x25	300.241 A	302.242 B	GIORGI GM 20-32

Poz. 3

KOD	poloha	H	A	S	C	Kod těleso	Kod držáku	STROJ
306.101	SPODNÍ	22	40	12	13x3	306.101 A	306.101 B	TRAUB A 15-20-25 / SAIC B26 / ITS 26
306.201	HORNÍ	22	40	12	13x3	306.201 A	306.201 B	TRAUB A 15-20-25 / SAIC B26 / ITS 26
306.601	SPODNÍ	40	60	15	17x4	306.601 A	306.601 B	TRAUB A 36-42-60 TB 42-60 / SAIC B45 / ITS 60
306.701	HORNÍ	40	60	15	17x4	306.701 A	306.701 B	TRAUB A 36-42-60 TB 42-60 / SAIC B45 / ITS 60

DRŽÁK KOTOUČOVÉHO NOŽE PRO PŘÍČNÝ SUPORT

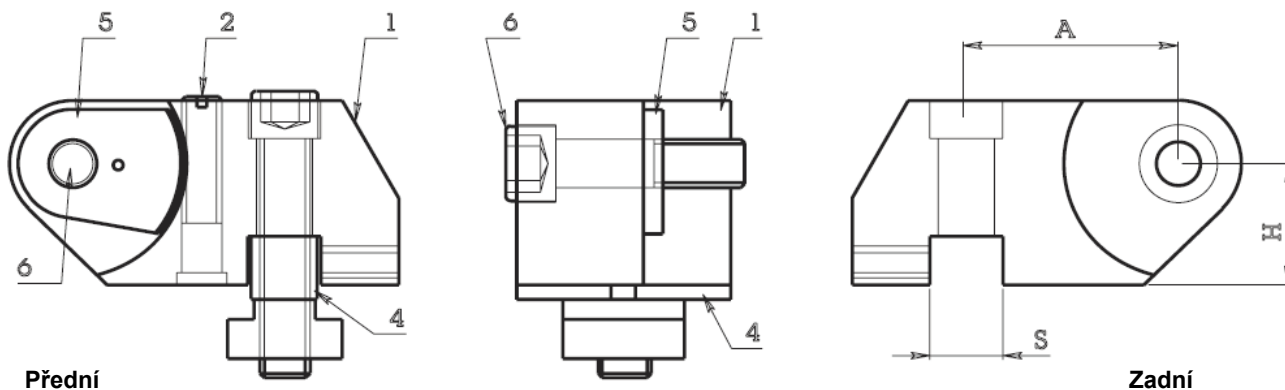

Kod - přední	H	A	S	D	h	Kod - zadní	STROJ
	22	43	12	44	25		
310.100	n° 0 - Držák kompletní					310.200	TRAUB A 15-20-25 SAIC B 26-30 ITS 26
310.101	n° 1 - Základna					310.201	
310.102	n° 2 - Šroub					310.202	
310.104	n° 4 - Pero					310.104	
310.105	n° 5 - Ozubený segment					310.105	
310.106	n° 6 - Šroub					310.106	

DRŽÁK PLOCHÉHO NOŽE PRO PŘÍČNÝ SUPORT DVOJITÝ A TROJITÝ

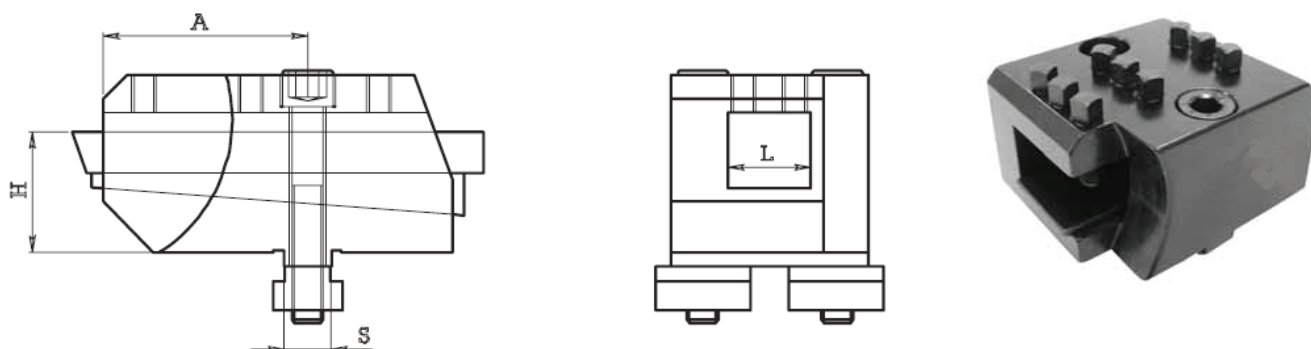

VYOBRAZENÝ DRŽÁK JE PRO PŘEDNÍ SUPORT

KOD	poloha	H	A	S	L	nástroj	STROJ
320.102	SPODNI	22	38	12	22	10x20	TRAUB A 15-20-25 / SAIC B26 / ITS 26 / GIORGI GM 20-25-32
320.103	SPODNI	22	38	12	33	10x30	TRAUB A 15-20-25 / SAIC B26 / ITS 26 / GIORGI GM 20-25-32
320.202	HORNÍ	22	38	12	22	10x20	TRAUB A 15-20-25 / SAIC B26 / ITS 26 / GIORGI GM 20-25-32
320.203	HORNÍ	22	38	12	33	10x30	TRAUB A 15-20-25 / SAIC B26 / ITS 26 / GIORGI GM 20-25-32
320.602	SPODNI	40	65	15	27	12x25	TRAUB A 36-42-60 TB 42-60 / SAIC B45 / ITS 60
320.603	SPODNI	40	65	15	41	12x40	TRAUB A 36-42-60 TB 42-60 / SAIC B45 / ITS 60
320.702	HORNÍ	40	65	15	27	12x25	TRAUB A 36-42-60 TB 42-60 / SAIC B45 / ITS 60
320.703	HORNÍ	40	65	15	41	12x40	TRAUB A 36-42-60 TB 42-60 / SAIC B45 / ITS 60

DRŽÁK PLOCHÉHO NOŽE S KLÍNEM PRO PŘÍČNÝ SUPORT

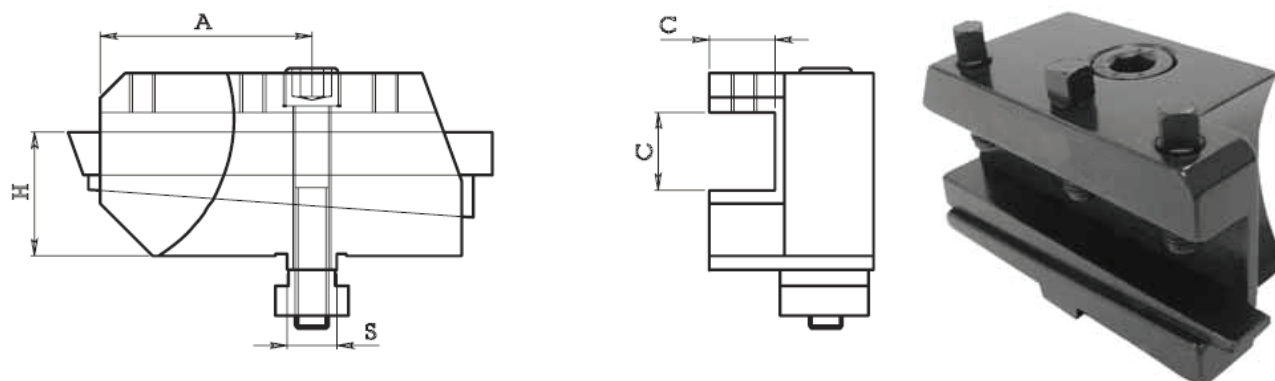

VYOBRAZENÝ DRŽÁK JE PRO PŘEDNÍ SUPORT

KOD	poloha	H	A	S	C	STROJ
330.101	PŘEDNÍ	22	38	12	10x10	TRAUB A 15-20-25 / SAIC B26 / ITS 26 / GIORGI GM 20-25-32
330.201	ZADNÍ	22	38	12	10x10	TRAUB A 15-20-25 / SAIC B26 / ITS 26 / GIORGI GM 20-25-32
330.111	PŘEDNÍ	30	50	10	12x12	TRAUB TD 16-26-36
330.211	ZADNÍ	30	50	10	12x12	TRAUB TD 16-26-36
330.601	PŘEDNÍ	40	62,5	15	12x12	TRAUB A 36-42-60 TB 42-60 / SAIC B45 / ITS 60
330.701	ZADNÍ	40	62,5	15	12x12	TRAUB A 36-42-60 TB 42-60 / SAIC B45 / ITS 60

KLÍN DO DRŽÁKU PLOCHÉHO NOŽE

KOD	H	L
334.101	10	85
334.102	20	85
334.103	30	85
334.601	15	120
334.602	25	120
334.603	40	120

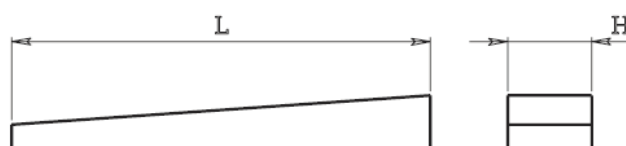

T - MATICE

KOD	d	H	S	Poz.
336.110	M10	12	20	1
336.112	M12	12	20	1
336.210	M10	12	20	2
336.610	M10	15	22	1
336.612	M12	15	22	1
336.614	M14	15	22	1

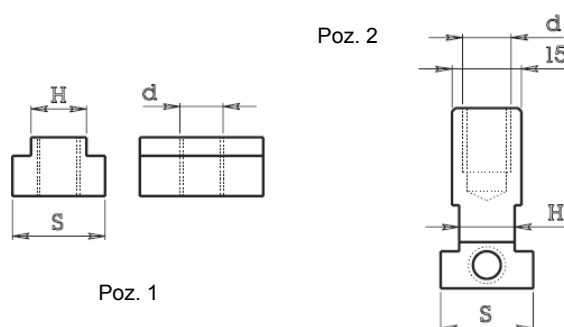

NARÁŽKY PRO REVOLVEROVOU HLAVU

KOD	d	S	Poz.	STROJ
336.901 D	6,5	8	4	INDEX 12-18-25
336.901 S	6,5	8	3	
336.903 D	8,2	10	2	INDEX 24-36-52
336.903 S	8,2	10	1	
336.904 D	8,2	10	4	INDEX 36-42-52
336.904 S	8,2	10	3	

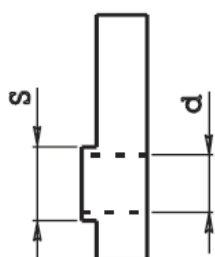

LEVÁ



Poz. 1

PRAVÁ



Poz. 2

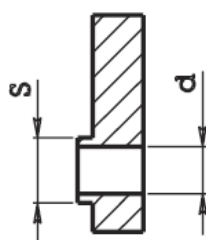

LEVÁ



Poz. 3

PRAVÁ



Poz. 4

ŠROUBY PRO NARÁŽKY

KOD	D	L	Q	Pro narážky
707.001	M6	22	12	336.901
707.002	M8	25	14	336.903

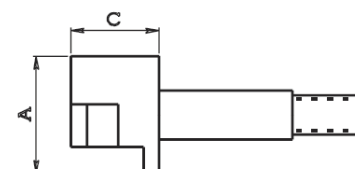
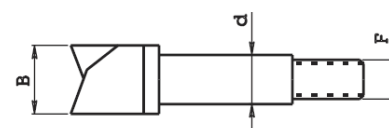
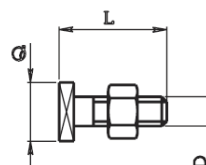

KOD	d	A	B	C	F	STROJ
336.907	8	21	12	15	M7x1	INDEX 12-18-25
336.908	10	24	14	18	M8x1	INDEX 36-52
336.908 B	10	18	14	18	M8x1	INDEX C19-29 INDEX B30-42-60

RÁDLOVACÍ DRŽÁK

KOD	Rozm.	L	d	Kod čepu	D	S	Poz.
340.006	6x6	120	4	736.903	12	4	1
340.007	7x7	120	4	736.903	12	4	1
340.008	8x8	120	4	736.903	12	4	1
340.010	10x10	120	4	736.903	12	4	1
340.106	6x6	120	5	736.901	15	5	1
340.107	7x7	120	5	736.901	15	5	1
340.108	8x8	120	5	736.901	15	5	1
340.110	10x10	120	5	736.901	15	5	1
340.112	12x12	120	5	736.901	15	5	1
340.210	10x10	120	6	736.902	20	6	1
340.212	12x12	120	6	736.902	20	6	1
340.310	10x10	120	6	736.902	20	8	1
340.312	12x12	120	6	736.902	20	8	1
340.316	16x16	120	6	736.902	20	8	1
340.410	10x10	120	6	736.904	20	10	1
340.412	12x12	120	6	736.904	20	10	1
341.008	8x8	120	4	736.903	12	4	2
341.108	8x8	120	5	736.901	15	5	2
341.110	10x10	120	5	736.901	15	5	2
341.310	10x10	130	6	736.902	20	8	2
341.312	12x12	130	6	736.902	20	8	2

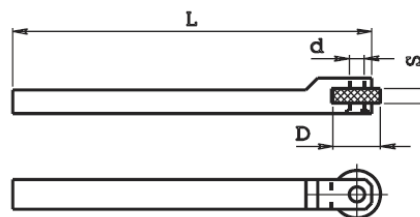

Poz. 1

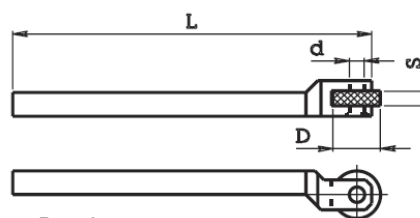

Poz. 2

NÁHRADNÍ ČEP DO DRŽÁKU			
KOD	D	L	S
736.901	5	14	11
736.902	6	18	15
736.903	4	14	11
736.904	6	20	17

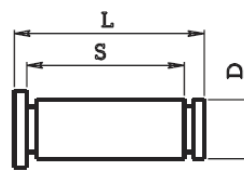
DRŽÁK JE DODÁVÁN
S ČEPEM

RÁDLOVACÍ KOLEČKA

JAKÉKOLIV NA OBJEDNÁVKU

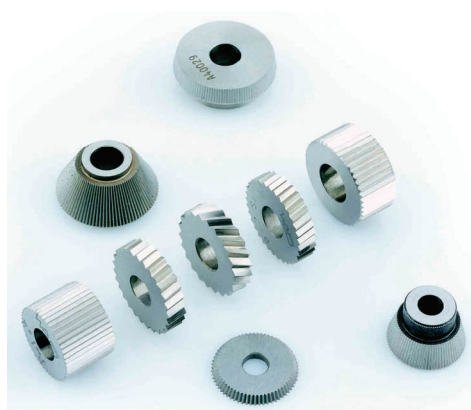

PŘÍRUBA PRO DRŽÁKY

KOD	D	d	L	h	H	STROJ
360.101	30	15	98	38	48	TRAUB A15-20-25
360.201	36	15	98	38	48	SAIC B26
360.202	32	15	98	38	48	GIORGI GM25-32
360.601	40	22	126	40	58	TRAUB A36-42-60 TB42-60
360.801	42	22	126	40	58	SAIC B45

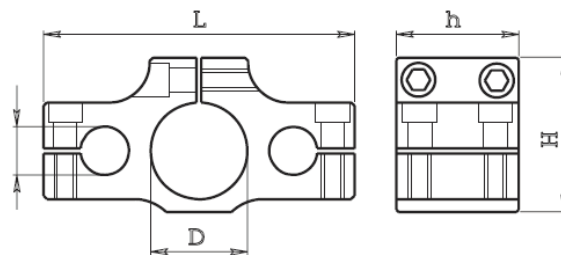

DRŽÁK DO PŘÍRUBY

KOD	C	d	L	H	Pro přírubu
120.202	0°	15	60	18	360.101 - 360.201 - 360.202
120.212	8°	15	60	18	360.101 - 360.201 - 360.202
120.232	30°	15	60	29	360.101 - 360.201 - 360.202
120.246	45°	15	60	42	360.101 - 360.201 - 360.202
362.601	0°	22	85	24	360.601 - 360.801
362.615	15°	22	85	27	360.601 - 360.801
362.630	30°	22	85	40	360.601 - 360.801
362.645	45°	22	85	55	360.601 - 360.801

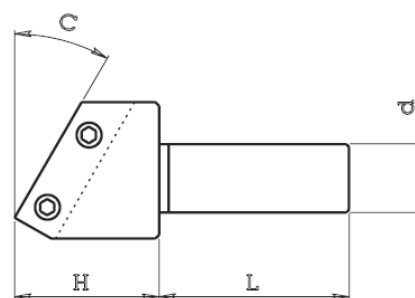

DRŽÁK DO PŘÍRUBY

KOD	d	L	H	Pro přírubu
124.202	15	60	40	360.101 - 360.201 - 360.202
364.601	22	85	40	360.601 - 360.801

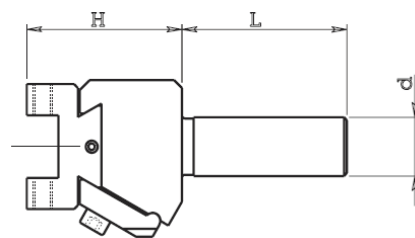

DRŽÁK DO PŘÍRUBY

KOD	C	d	L	H	S	STROJ
366.030	30°	23	36	25	8x8	SAIC B26 (Závitování)
366.031	30°	25	36	25	8x8	GIORGI 25 (Závitování)
366.032	30°	26	36	25	8x8	ITS 26
366.100	0°	30	70	26	8x8	TRAUB A1 5-20-25
366.115	15°	30	70	26	8x8	TRAUB A1 5-20-25
366.130	30°	30	75	26	8x8	TRAUB A1 5-20-25
366.145	45°	30	80	26	8x8	TRAUB A1 5-20-25
366.215	15°	36	70	27	10x10	SAIC B26
366.245	45°	36	80	27	10x10	SAIC B26
366.615	15°	40	80	32	10x10	TRAUB A36-42-60 TB42-60
366.630	30°	40	80	32	10x10	TRAUB A36-42-60 TB42-60
366.645	45°	40	90	32	10x10	TRAUB A36-42-60 TB42-60
366.845	45°	42	90	32	10x10	SAIC B45

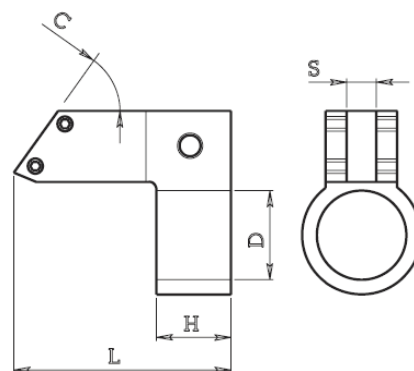

POUZDRO S KUŽELEM MORSE - OBOUSTRANNÉ

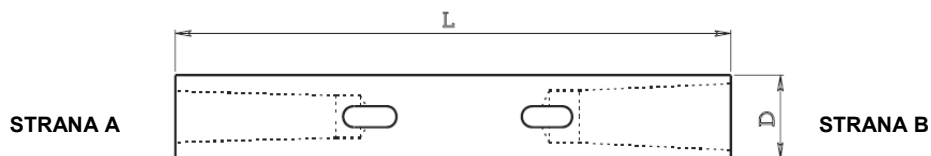

KOD	A	B	D	L	STROJ
372.112	1	2	30	200	TRAUB A1 5-20-25 TD16-26-36
372.113	1	3	30	200	TRAUB A1 5-20-25 TD16-26-36
372.123	2	3	30	200	TRAUB A1 5-20-25 TD16-26-36
372.201	1	2	32	200	GIORGI GM20-25-32
372.202	2	3	32	200	GIORGI GM20-25-32
372.223	2	3	36	200	SAIC B26

KOD	A	B	D	L	STROJ
372.623	2	3	40	270	TRAUB A36-42-60 TB42-60
372.624	2	4	40	270	TRAUB A36-42-60 TB42-60
372.634	3	4	40	270	TRAUB A36-42-60 TB42-60
372.824	2	4	42	270	SAIC B45
372.834	3	4	42	270	SAIC B45

TÁHLA

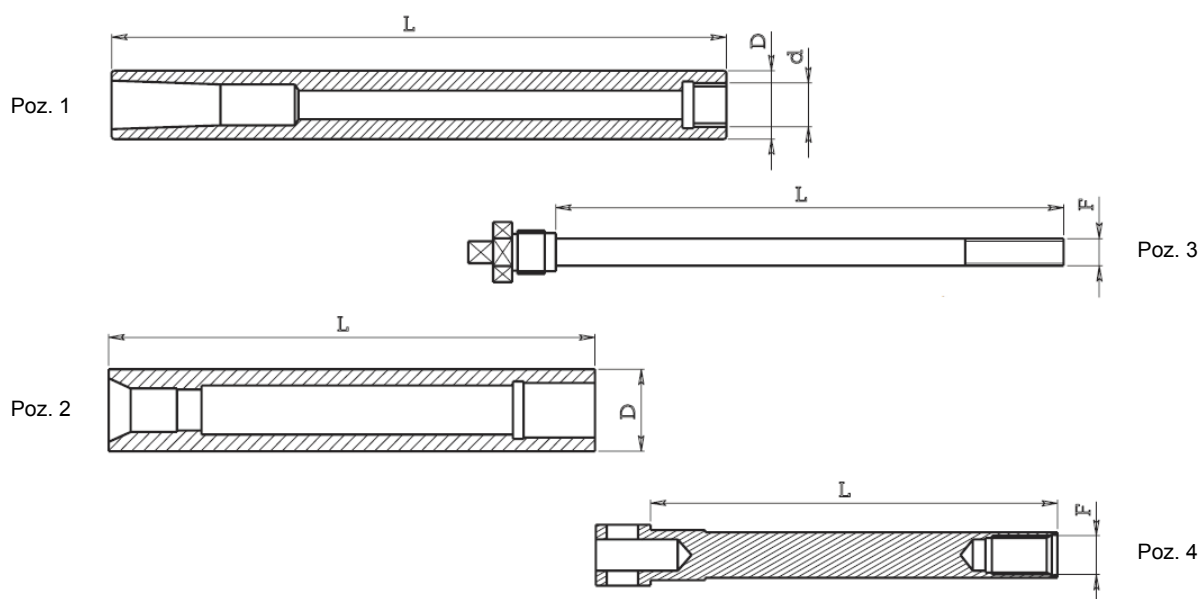

Kod pouzdra	Poz.	d	D	L	Kod kleš.	Kod táhla	Poz.	F	L	STROJ	FUNKCE
374.023	1	M16x1 L	23	250	020.200	376.023	3	M10	184	SAIC B26	závitorez
374.025	1	M16x1 L	25	225	020.200	376.025	3	M10	159	GIORGI 25	závitorez
374.026	1	M16x1 L	26	225	020.200	376.026	3	M10	159	ITS 26	závitorez
374.030	2	—	30	230	018.020	376.030	4	M13x1	190	TRAUB A15-20-25	závitorez
374.101	2	—	30	178	018.020	376.101	4	M13x1	138	TRAUB A15-20-25	podepření
374.201	1	M16x1 L	36	190	020.200	376.201	3	M10	125	SAIC B26	podepření
374.202	1	M16x1 L	30	190	020.200	376.201	3	M10	125	ITS 26	podepření
374.203	1	1M6x1 L	32	190	020.200	376.201	3	M10	125	GIORGI 32	podepření
374.204	1	M25x1,5	32	210	020.300	376.204	3	M12	126	GIORGI 32	podepření
374.601	2	—	40	268	018.046	376.601	4	M23x1	202	TRAUB A36-42-60 TB42-60	podepření
374.801	1	M25x1,5	42	250	020.300	376.801	3	M12	166	SAIC B 45	podepření
374.802	2	—	42	269	018.046	376.601	4	M23X1	202	SAIC B45	podepření

DRŽÁK ZÁVITOVÉHO OČKA PRO DLOUHOTOČNÉ AUTOMATY

KOD	D	S	d	H
380.116	16	5	6	39
380.116 B	16	5	8	39
380.120	20	5	6	42
380.120 B	20	5	8	42
380.120 C	20	7	6	42
380.120 D	20	7	8	42
380.125	25	9	8	50
380.125 B	25	9	10	50
380.130	30	11	8	56
380.130 B	30	11	10	56
380.135	35	12	10	56
380.135 B	35	12	8	56
380.138	38	10	12	56
380.138 C	38	14	12	56

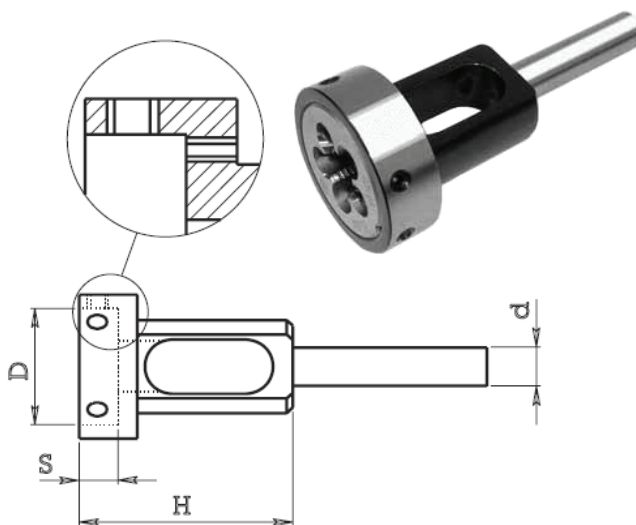

DRŽÁK ZÁVITOVÉHO OČKA PRO DLOUHOTOČNÉ AUTOMATY S MATICÍ

KOD	D	d	H
380.616	16	6	39
380.616 B	16	8	39
380.620	20	6	42
380.620 B	20	8	42
380.625	25	8	50
380.625 B	25	10	50
380.630	30	8	56
380.630 B	30	10	56
380.635	35	10	56

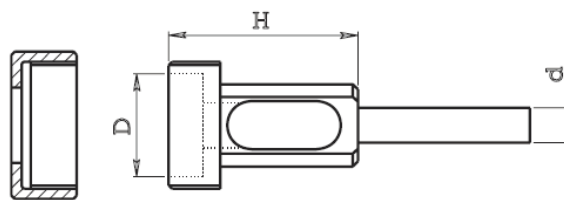

380.616 1	Matice pro kod 380.616
380.620 1	Matice pro kod 380.620
380.625 1	Matice pro kod 380.625
380.630 1	Matice pro kod 380.630

DRŽÁK ZÁVITOVÉHO OČKA PRO ZÁVITOŘEZ

TRAUB A15-20-25

KOD	D	H	L	F	KOD	D	H	L	F	KOD	D	H	L	F
382.112	12	4	32	M25x1,5	382.212	12	4	46	M25x1,5	382.312	12	4	62	M25x1,5
382.116	16	5	32	M25x1,5	382.216	16	5	46	M25x1,5	382.316	16	5	62	M25x1,5
382.120	20	7	32	M25x1,5	382.220	20	7	46	M25x1,5	382.320	20	7	62	M25x1,5
382.125	25	9	32	M25x1,5	382.225	25	9	46	M25x1,5	382.325	25	9	62	M25x1,5
382.130	30	11	32	M25x1,5	382.230	30	11	46	M25x1,5	382.330	30	11	62	M25x1,5
382.138	38	14	32	M25x1,5	382.238	38	14	46	M25x1,5	382.338	38	14	62	M25x1,5

SAIC B26-30 / ITS 26 / GIORGI 20-25-30

KOD	D	H	L	F	KOD	D	H	L	F	KOD	D	H	L	F
382.412	12	4	32	M26x1,5	382.512	12	4	46	M26x1,5	382.612	12	4	62	M26x1,5
382.416	16	5	32	M26x1,5	382.516	16	5	46	M26x1,5	382.616	16	5	62	M26x1,5
382.420	20	7	32	M26x1,5	382.520	20	7	46	M26x1,5	382.620	20	7	62	M26x1,5
382.425	25	9	32	M26x1,5	382.525	25	9	46	M26x1,5	382.625	25	9	62	M26x1,5
382.430	30	11	32	M26x1,5	382.530	30	11	46	M26x1,5	382.630	30	11	62	M26x1,5
382.438	38	14	32	M26x1,5	382.538	38	14	46	M26x1,5	382.638	38	14	62	M26x1,5

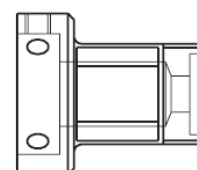
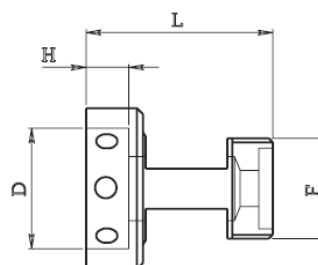

DRŽÁK ZÁVITOVÉHO OČKA

KOD	D	H	d	L
384.116	16	5	9	60
384.120	20	7	9	60
384.125	25	9	9	60
384.130	30	11	9	60
384.138	38	10	12	60
384.138 B	38	14	12	60
384.145	45	14	15	66
384.145 B	45	18	15	66

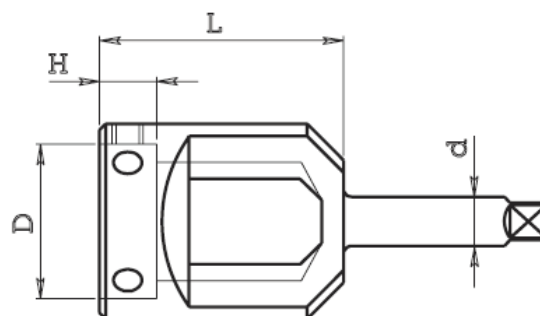

KOD	D	H	L	Kužel
384.716	16	5	60	Morse 2
384.720	20	7	60	Morse 2
384.725	25	9	60	Morse 2
384.730	30	11	60	Morse 2
384.738	38	10	60	Morse 2
384.738 B	38	14	60	Morse 2
384.745	45	14	66	Morse 2
384.745 B	45	18	66	Morse 2

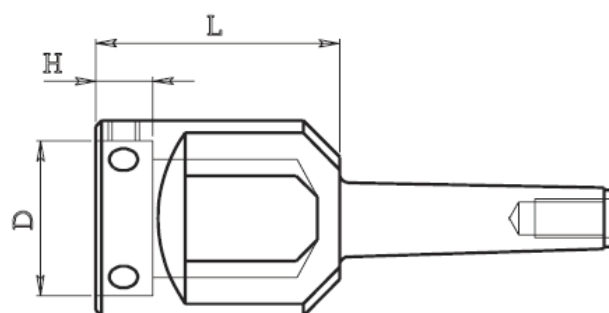

UNÁŠECÍ ČEP PRO KUŽEL MORSE 2

KOD 164.992

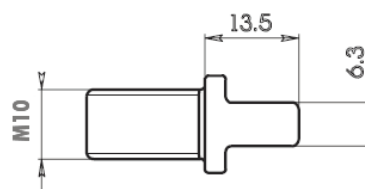

DRŽÁK ZÁVITOVÉHO OČKA

KOD	D	H	d	L
380.525	25	9	20	35
380.530	30	11	20	35
380.538	38	10	20	35
380.538B	38	14	20	40
380.545	45	14	20	40
380.545B	45	18	20	40
380.550	50	16	20	40
380.555B	55	16	20	40

