

I - 1

KLEŠTINY A PŘÍSLUŠENSTVÍ

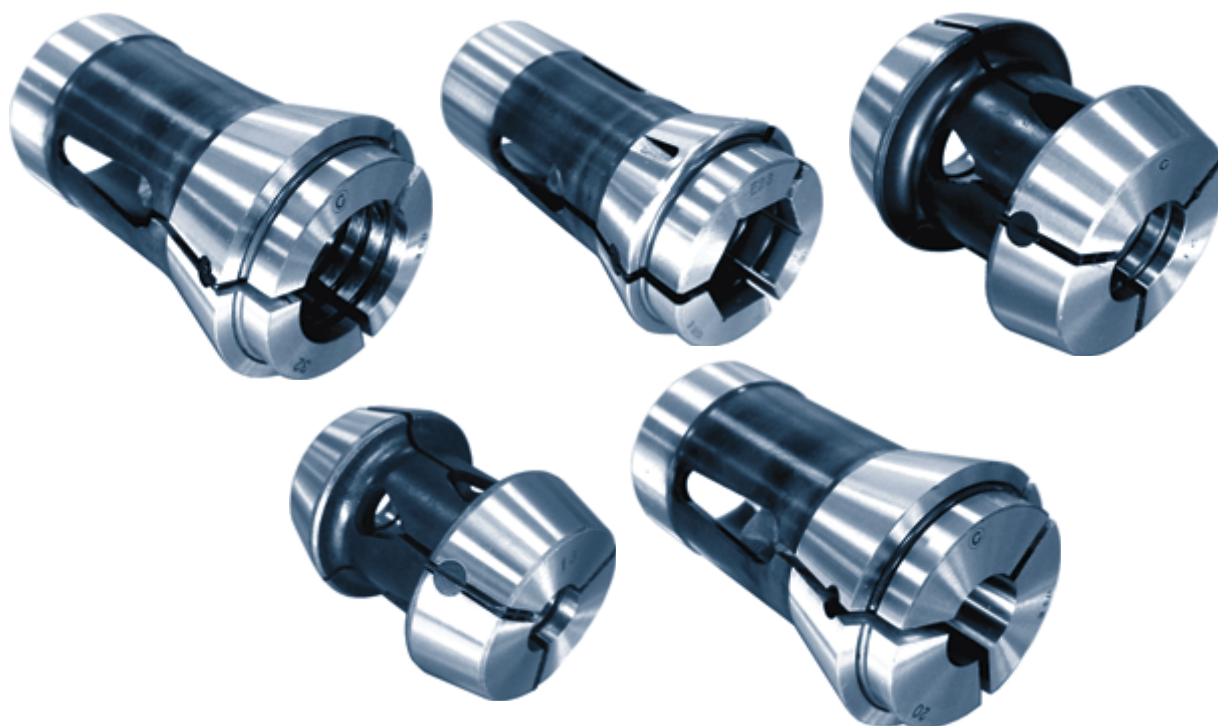

NTA s.r.o.
Komenského 365
763 16 Fryšták
www.nta.cz ntaoffice@nta.cz

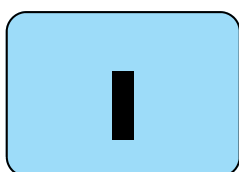

MĚŘENÍ PŘESNOSTI



Upínací otvor		L	Max. úchylka
0,5	1	3	0,015
1	1,6	6	0,02
1,6	3	10	0,02
3	6	16	0,02
6	10	25	0,02
10	18	40	0,03
18	24	50	0,03
24	30	60	0,03
30	50	80	0,04
50		100	0,04

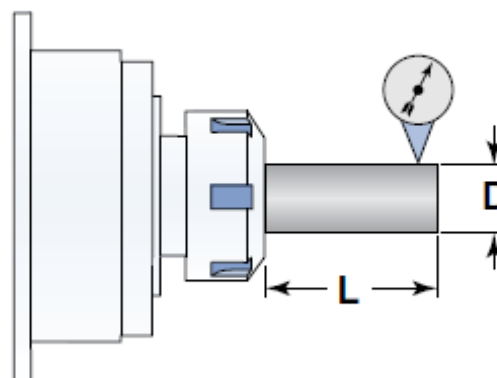

Varianty otvorů kleštin

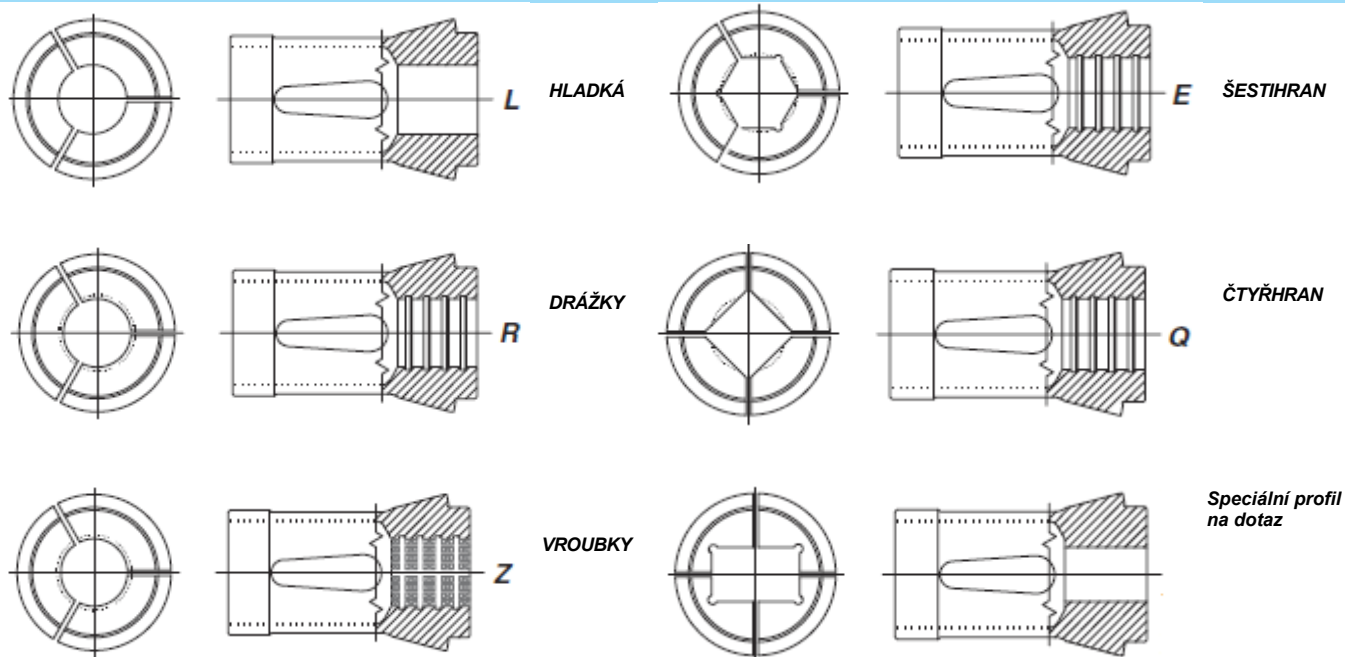

KLEŠTINY

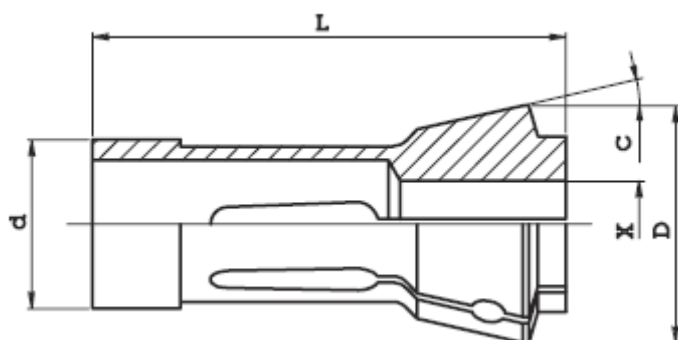

KOD		d	D	L	C	otvor max.		
						L	E	Q
010.006	101 E	8	12	42	16°	6	—	—
010.013	110 E	10	16	43	15°	7	—	—
010.014	109 E	10	16	47	20°	7	6	5
010.019		12	17	27	20°	8.5	—	—
010.025	117 E	14	18	46	13°	10	8	7
010.027		12	18	64	16°	10	8	7
010.028	116 E	13	19	64	16°	10	8	7
010.029	120 E	15	21	64	16°	12	10	9
010.030	121 E	15	22	47	20°	10	9	7
010.032	123 E	16	22	55	15°	12	10	7
010.036		18	23	52		13	—	—
010.038	127 E	18	25	67	15°	12	10	9
010.042	136 E	20	26	54	15°	16	12	10
010.043	1299 E	20	27,5	60	15°	17	15	12
010.045	138 E	20	28	67	16°	16	12	10
010.049	139 E	22	28	67	13°	16	12	10
010.051	140 E	22	30	55	15°	18	15	12
010.053	1323 E	22	32	66	16°	18	15	12
010.060	143 E	25	31	54	15°	21	18	15
010.063	144 E	25	34	65	15°	20	17	14
010.064	145 E	25	35	77	16°	20	17	14

KOD		d	D	L	C	otvor max.		
						L	E	Q
010.065	146 E	26	32	67	13°	20	17	14
010.067	147 E	27	38	72,7	15°	23	19	16
010.070	148 E	28	38	70	15°	23	20	16
010.074	1446 E	30	38	65	15°	25	22	18
010.078	157 E	30	42	80	16°	25	22	18
010.084	161 E	32	45	75	15°	26	22	18
010.086	1473 E	32	40	65	15°	26	22	18
010.092	162 E	35	43	70	15°	25	22	18
010.093	163 E	35	48	80	15°	30	26	22
010.101	1536 E	37	47	92	16°	32	30	22
010.102		38	50,3	86	15°	32	29	22
010.111	171 E	42	55	94	15°	36	32	25
010.117	173 E	48	60	94	15°	42	36	30
010.121		52	63	92	15°	46	38	32
010.122		52	65	94	15°	46	38	32
010.127	177 E	58	70	94	15°	52	45	36
010.130		60	72	102	15°	54	40	32
010.133	185 E	66	84	110	15°	60	52	42
010.140		80	98	115	15°	70	60	50
010.147		95	117	125	15°	80	68	56
010.150		115	135	140	15°	100	86	80

DORAZY PRO KLEŠTINY

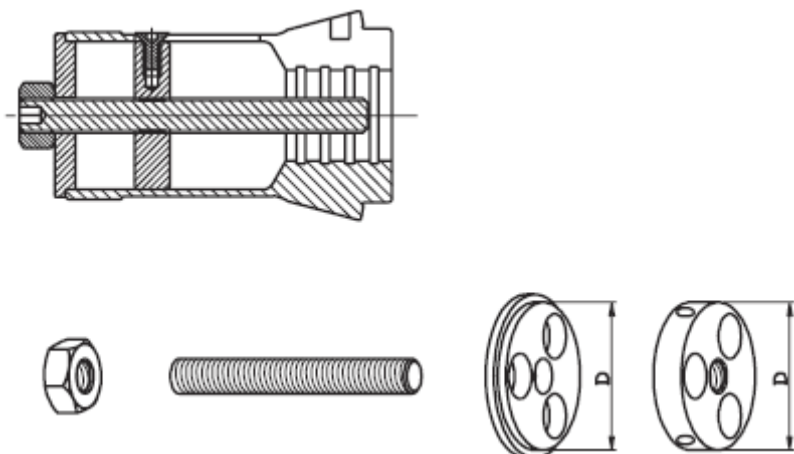

KOD	Pro kleštinu	D
011.051	010.051	17
011.084	010.084	26
011.117	010.117	42,5
011.127	010.127	52,3
011.133	010.133	60,5

PODÁVACÍ KLEŠTINY

KOD		D	d	L	F	otvor max.		
						L	E	Q
012.007	207 E	18	16	70	16x1L	12	11	9
012.009	217 E	21,5	20,5	70	20x1L	16	14	11
012.025	220 E	24	22	85	22x1L	18	16	13
012.037	236 E	30	29	95	28x1L	25	22	17
012.038	237 E	31	29	90	29x1L	25	22	17
012.052		36	35	116	34x1L	30	26	20
012.060	254 E	42	40	116	40x1L	36	30	25
012.073	260 E	52	50	116	50x1L	46	40	32
012.077		54	52	130	51x1L	46	40	32
012.083	273 E	60	58	140	58x1L	52	45	36

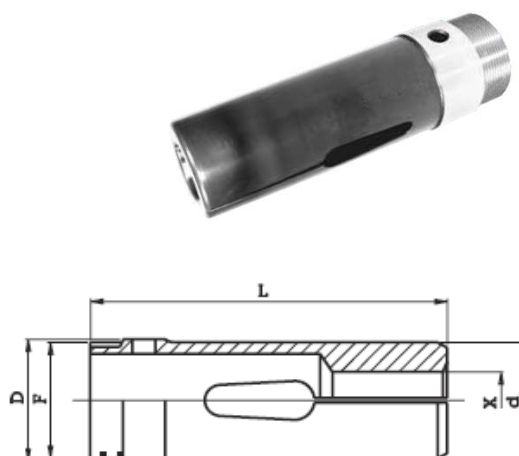

ADAPTÉRY PRO PODÁVACÍ KLEŠTINY

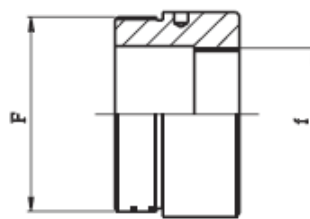

KOD	F	f	od	do	STROJ
013.101	22x1L	16x1L	012.025	012.007	INDEX 18 redukce na INDEX 12
013.102	28x1L	22x1L	012.037	012.025	INDEX 24 redukce na INDEX 18
013.103	29x1L	22x1L	012.038	012.025	INDEX 25 redukce na INDEX 18
013.104	40x1L	28x1L	012.060	012.037	INDEX 36/B42 redukce na INDEX 24/B30
013.105	40x1L	29x1L	012.060	012.038	INDEX 36/B42 redukce na INDEX 25
013.106	58x1L	40x1L	012.083	012.060	INDEX 52/B60 redukce na INDEX 36/B42

PODÁVACÍ KLEŠTINY

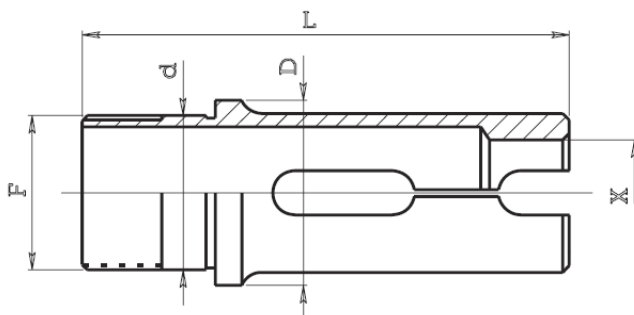

KOD		D	d	L	F	otvor max.		
						L	E	Q
014.003	242 E	42	36	120	36x1,5	30	26	21
014.006	259 E	56	50	138	50x1,5	42	36	29
014.012	278 E	75	68	138	68x1,5	60	52	42

KLEŠTINY S DVOJITÝM KUŽELEM

KOD	D	L	C	otvor max.		
				L	E	Q
016.024	34	56	17°30'	26	22	18
016.052	34,5	74	25°	26	22	18
016.054	26	55	25°	15	13	10
016.055	50	80	20°	36	31	25
016.043	60	80	17°	45	39	30
016.056	69,5	100	18°	60	52	42
016.051	70	80	16°	52	43	36
016.057	72	100	17°	56	50	40
016.062	81	90	17°	60	52	42
016.070	91	100	17°	70	62	50
016.080	108	105	17°	80	68	56
016.100	130	120	17°	100	86	70
016.120	155	130	16.45°	120	105	95

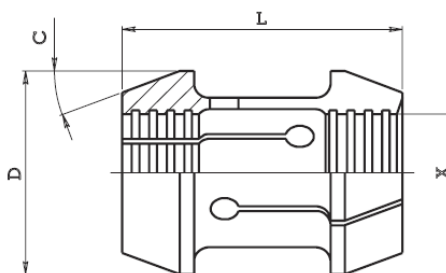

UPÍŇACÍ KLEŠTINY

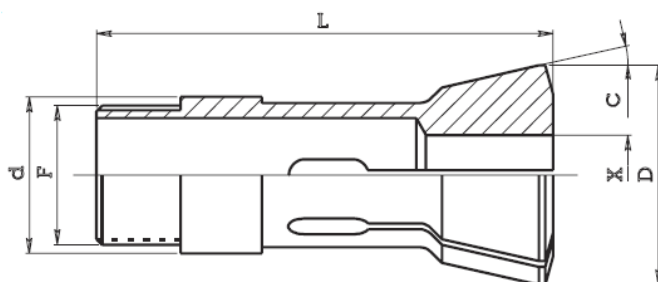

KOD		d	D	L	C	F	otvor max.		
							L	E	Q
018.020	324E	15	21,5	55	20°	13x1	13	—	—
018.028		20	26,3	73	15°	19,7x1,66	20	—	—
018.046		25	33,5	87,5	16°	23x1	22	—	—
018.048		25	337	97,6	15°	24,7x1,5	25	20	16

KLEŠTINY S KUŽELEM MORSE

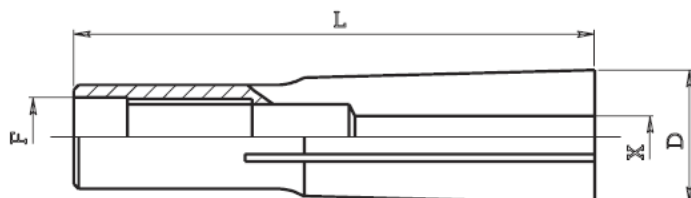

KOD	D	L	F	K.M.	X		po	STROJ
					Min.	Max.		
020.200	18	69	M10	2	2	14	0,25	GIORGI GM20-25-30-32 / ITS TCA 301 / SAIC B26 DUPLOMATIC FR50 / STEINEL SH1 -SV1 -SV3-5 / BRIDGEPORT M (F3/8"-16)
020.300	24	86	M12	3	2	18	0,5	CLARKSON MARK1 / RAVETTA PB32DUPLOMATIC FR70 ITS 36-60 / SAIC B45

KLEŠTINY PRO PODAVAČE

KLEŠTINY S PRAVÝM ZÁVITEM

KOD	d	L	F	X min.	X max.	ZÁSOBNÍK
036.070	7,5	40	5x0,5	1,6	6,5	IEMCA
036.100	10	50	6x0,75	2	8	CUCCHI
036.101	10	40	6x0,75	2	8	IEMCA
036.120	12	52	7x0,75	2	10,5	CUCCHI
036.121	12	42	7x0,75	2	10,5	IEMCA
036.140	14	52	8x1	3	12,5	CUCCHI
036.150	15	52	8x1	2	13,5	CUCCHI
036.151	15	42	8x1	2	13,5	IEMCA
036.160	16	52	8x1	10	14	CUCCHI
036.161	16	42	8x1	10	14	IEMCA
036.180	18	59	10x1	4	16	CUCCHI
036.200	20	59	10x1	3	18	CUCCHI, IEMCA
036.220	22	59	10x1	16	20	CUCCHI a IEMCA
036.250	25	59	10x1	4	23	IEMCA
036.251	25	59	14x1	4	23	CUCCHI
036.300	30	65	10x1	8	28	IEMCA
036.301	30	65	18x1,5	10	28	CUCCHI
036.320	32	65	10x1	29	30	IEMCA
036.400	40	70	25x1,5	10	37	CUCCHI, IEMCA
036.420	42	70	25x1,5	38	39	CUCCHI, IEMCA
036.460	46	72	25x1,5	37	42	CUCCHI, IEMCA
036.550	55	80	25x1,5	43	51	CUCCHI, IEMCA (1)
036.600	60	80	25x1,5	30	55	CUCCHI, IEMCA
036.650	65	80	25x1,5	56	60	CUCCHI, IEMCA
036.700	69,5	80	25x1,5	61	65	CUCCHI, IEMCA
036.750	75	80	25x1,5	66	70	CUCCHI, IEMCA

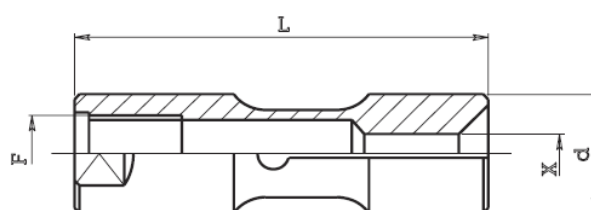

(1) NA DOTAZ

KLEŠTINY S LEVÝM ZÁVITEM

KOD	d	L	F	X min.	X max.	ZÁSOBNÍK
035.190	19	60	10x1 L	4	16	CUCCHI PB 20
035.200	20	60	10x1 L	17	18	CUCCHI PB 20
035.230	23	60	14x1 L	4	20	CUCCHI PB 24
035.250	25	60	14x1 L	20	23	CUCCHI PB 24
035.290	29	65	18x1,5 L	4	26	CUCCHI PB 30
035.300	30	65	18x1,5 L	26	27,5	CUCCHI PB 30
035.350	35	70	18x1,5 L	24	33	CUCCHI PB 35
035.370	37	70	25x1,5 L	10	34	CUCCHI PB 38
035.390	39	70	25x1,5 L	32	36	CUCCHI PB 40
035.410	41	70	25x1,5 L	36	38	CUCCHI PB 42
035.470	47	70	30x1,5 L	14	43	CUCCHI PB 48
035.490	49	70	30x1,5 L	44	45	CUCCHI PB 50
035.590	59	80	30x1,5 L	30	55	CUCCHI PB 60
035.650	65	80	30x1,5 L	56	60	CUCCHI PB 68
035.700	69,5	80	30x1,5 L	61	65	CUCCHI PB 70-72
035.750	75	80	30x1,5 L	66	70	CUCCHI PB 75

ROTAČNÍ SVORNÍKY K TLAČNÝM TYČÍM PODAVAČŮ

PRO „IEMCA“ S PRAVÝM ZÁVITEM

KOD	D	L	F	d	Poz.
516.007	7,5	126	6x0,75	5x0,5	1
516.010	10	113	8x1	6x0,75	1
516.012	12	116	10x1	7x0,75	1
516.015	15	121	12x1,5	8x1	1
516.020	20	133	14x1,5	10x1	1
516.025	25	133	14x1,5	10x1	1
516.030	30	135	14x1,5	10x1	1



PRO „CUCCHI“ S PRAVÝM ZÁVITEM

KOD	D	L	F	d	Poz.
517.010	10	107	7x1	6x0,75	2
517.012	12	107	8x1,25	7x0,75	2
517.014	14	107	10x1,5	8x1	2
517.016	16	107	10x1,5	8x1	2
517.019	19	118	12x1,75	10x1	2
517.025	25	118	20x1,5	14x1	2
517.030	30	123	24x1,5	18x1,5	2
517.040	40	61	28x1,5	25x1,5	4

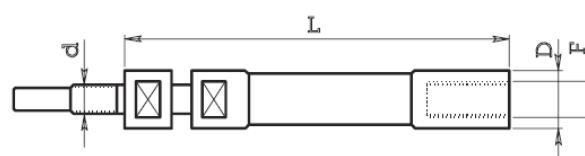

Poz.1

PRO „CUCCHI“ S LEVÝM ZÁVITEM

KOD	D	L	F	d	Poz.
517.120	19	100	17x1L	10x1L	2
517.120P	19	100	17x1L	14x1,5L	2
517.120S	19	105	17x1L	10x1L	3
517.125	24	100	20x1,5L	14x1L	2
517.125P	24	100	20x1,5L	20x1,5L	2
517.125S	24	105	20x1,5L	14x1L	3
517.130	29,3	100	26x1,5L	18x1,5L	2
517.130S	29,3	100	26x1,5L	18x1,5L	3
517.130P	29,3	100	26x1,5L	26x1,5L	2
517.135	35	100	30x1,5L	18x1,5L	2
517.135P	35	100	30x1,5L	30x1,5L	2
517.138	38	83	30x1,5L	25x1,5L	2
517.138P	38	83	30x1,5L	30x1,5L	2
517.145	45	100	36x1,5L	30x1,5L	2
517.145P	45	100	36x1,5L	36x1,5L	2
517.148	48	100	36x1,5L	30x1,5L	2
517.148P	48	100	36x1,5L	36x1,5L	2
517.160	60	113	50x1,5L	30x1,5L	2

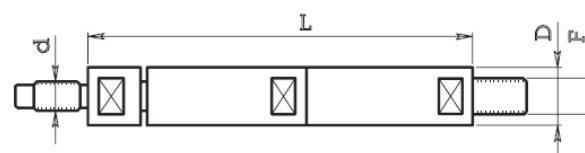

Poz.2

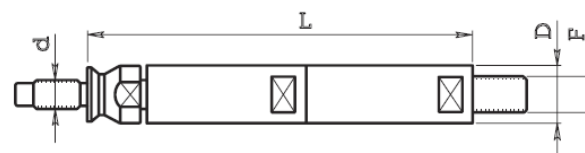

Poz.3

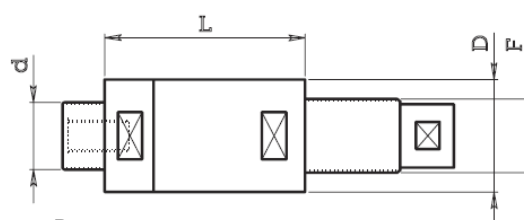

Poz.4

PRO „GIORGI“ S PRAVÝM ZÁVITEM

KOD	D	L	F	d	Poz.
517.719	19	92	14x1,5	10x1	2
517.728	28	100	20x1,5	14x1	2

KLEŠTINY PRO PODAVAČE

FMB—TRAUB—HAGENUK—IEMCA—ROBOBAR
LNS—SAMECA—MINISPRINT—MINITURBO

KOD	D	L	F	X min.	X max.	ØB	A	Poz.
034.135	5	37	M 4	1,5	4	-	-	2
034.107	7	37	M 5	2	5,5	-	-	2
034.110	10	40	7 H7	3	8	4,1	6	1
034.112	12	40	8 H7	3	10	4,1	6	1
034.115	15	40	11 H7	3	13	6,1	6	1
034.116	16	40	11 H7	3	14	6,1	6	1
034.118	18	40	11 H7	3	16	6,1	6	1
034.120	20	65	14 H7	4	18	8,1	7	1
034.125	25	65	20 H7	4	22	8,1	7	1
034.132	32	65	20 H7	10	29	8,1	7	1

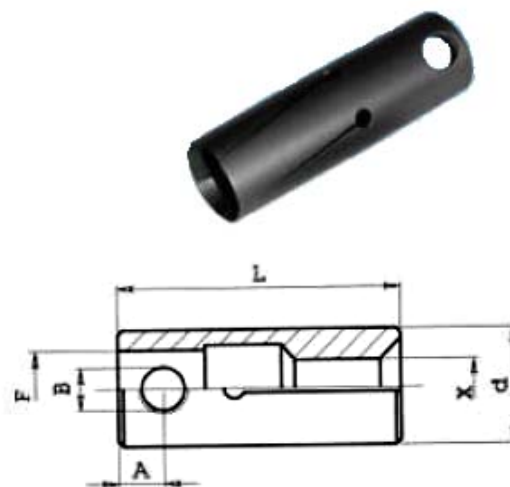

Poz.1

LNS - TRYTON

KOD	D	L	F	X min.	X max.	Poz.
034.006	6	30	M 4	1,5	4,5	2
034.007	7	30	M 4	2	5	2
034.010	10	30	M 5	2	8	2
034.012	12	30	M 6	3	9,5	2
034.013	12,5	30	M 6	9,5	10,5	2
034.017	16,5	35	M 8	4	14,5	2
034.020	20	35	M 10	4	18	2

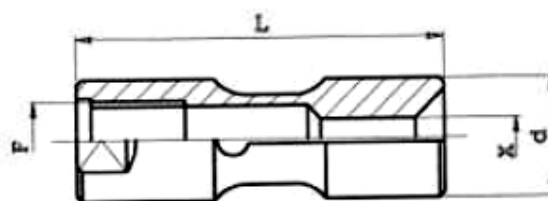

Poz.2

FMB—TRAUB—HAGENUK—IEMCA—ROBOBAR
LNS—SAMECA—MINISPRINT—MINITURBO

KOD	D	L	F	X min.	X max.	Poz.
034.225	25	90	20 H7	3	20	3
034.232	32	90	20 H7	5	29,5	3
034.336	36	90	20 H7	5	33	3

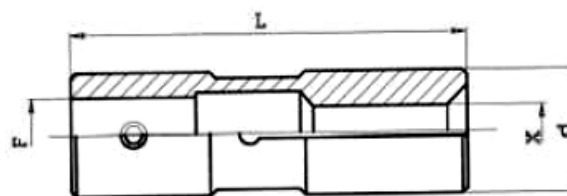

Poz.3

ROTAČNÍ SVORNÍKY K TLAČNÝM TYČÍM PODAVAČŮ

FMB—TRAUB—HAGENUK—LNS

KOD	D	L	F	d	Poz.
518.005	5,5	69	-	M4	1
518.007	7	78,5	M5	M5	1

FMB—HAGENUK

KOD	D	L	F	d	H	Poz.
518.110	10	45,5	8	7	31	2
518.112	12	45,5	8	8	31	2

FMB—HAGENUK—TRAUB

KOD	D	L	F	d	H	Poz.
518.115	15	50	12	11	31	2
518.118	18	50	12	11	31	2
518.120	20	50	17	14	31	2
518.125	25	50	20	20	31	2

TORNOS ROBOBAR

KOD	D	L	F	d	Poz.
518.205	5,5	78	M3	M4	1
518.207	7,5	78	5	M5	1
518.210	10,5	81	8	7	3
518.216	16	126	10	11	3
518.218	18	126	10	11	3
518.221	20,5	127	14	14	3
518.225	25	127	20	20	3
518.226	26	127	20	20	3
518.236	36	127	25	20	3

TRAUB—FMB—HAGENUK—LNS

KOD	D	L	F	d	Poz.
518.310	10	51	8	7	3
518.312	12	51	8	8	3
518.315	15	51	12	11	3
518.318	18	51	12	11	3
518.320	20	56	17	14	3
518.320B	20	51	12	11	3
518.325	25	58,5	20	20	3

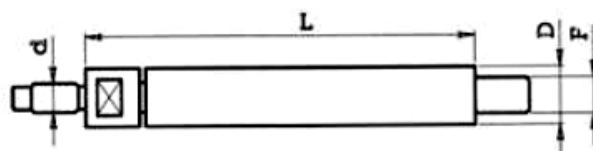

Poz.1

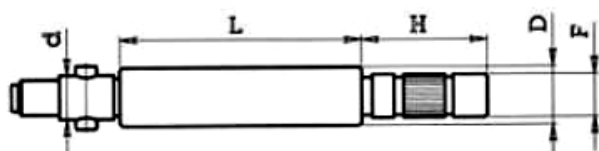

Poz.2

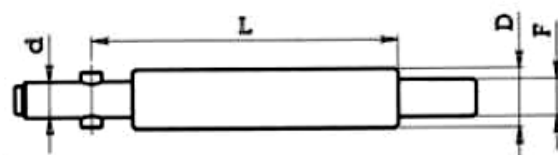

Poz.3

KLEŠTINY PRO ROTAČNÍ SVORNÍKY

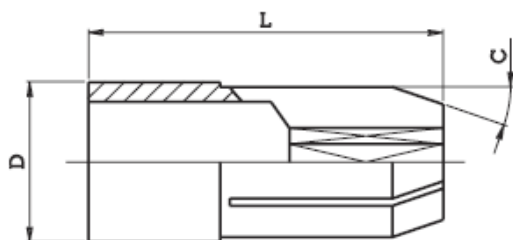

KOD	D	L	C	STROJE
039.110	9	30	19°	STROHM M4-5 / TORNOS M4-T4
039.130	15	35	19°	STROHM 105-125 / TORNOS M10-R10
039.150	16	35	19°	STROHM 105-125 / TOBRE 10 / TORNOS M10-R10
039.220	28	45	29°	STROHM 205 / TORNOS M20-RR20
039.230	32	45	19°	STROHM 255 / TORNOS M25

VODÍCÍ POUZDRA S VLOŽKOU SK

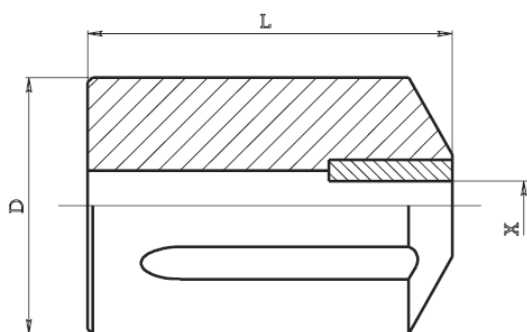

KOD	D	L	X max.	STROJE
040.011	10	18	4,5	STROHM M4-5 / TORNOS M3
040.020	13	30	8	PETERMAN 1-P4 / TORNOS M4-M6-T4-TV / BECHLER A7
040.031	15	30	10	STROHM M75-105-125 / TORNOS M7
040.040	16	30	10	PETERMAN P7-P7R / BECHLER A10 / STROHM M75-105-125
040.050	20	30	13	BECHET 1068-1268 / STROHM 125 / BECHLER A10 / PETERMAN 10-10H7
040.051	22	35	13	TORNOS R10
040.060	25	35	18	PETERMAN 10-10HS-10R-10HSR / OCEA THF25
040.073	32	45	24	STROHM 205-255 / TORNOS M15-R16-RR20-M25 / OCEA THF40
040.080	35	45	22	PETERMAN 2A-2AR-P16-P20
040.090	40	45	30	TORNOS M20-M25-M28 / BECHET 2568 / PETERMAN P25

VOĐÍCÍ POUZDRA S VLOŽKOU SK SEŘIZOVATELNÁ

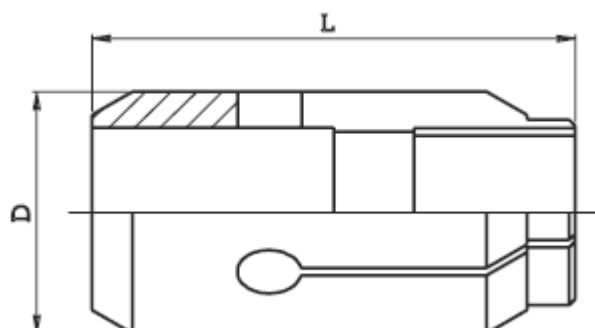

KOD	D	L	STROJE
041.108	8	30	BECHLER A4-A7
041.116	16	40	BECHLER A7-A1 0-AE1 0
041.120	20	40	BECHLER A10
041.130	30	60	BECHLER B12-16-20
041.134	34	60	BECHLER B12-16-20
041.142	42	72	BECHLER C26
041.148	48	73	BECHLER C32

VOĐÍCÍ POUZDRA S VLOŽKOU SK SEŘIZOVATELNÁ

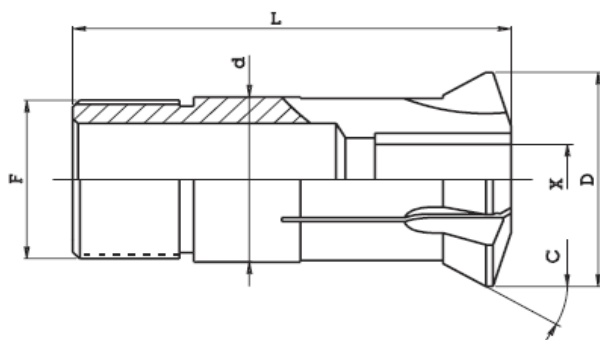

KOD	d	D	L	C	F	X max.	STROJE
042.010	7	9,5	30	16°	6x0,5	3,5	PETERMAN P3
042.030	9	11,5	25	30°	6x0,5 int.	4,5	PETERMAN P4
042.040	9	12,5	44	16°	8x0,75	4,5	TORNOS M4-T4-TV / PETERMAN P4 / CITIZEN L10-L10 WATCH
042.050	9	13	52	30°	9x0,7	4,5	TORNOS M4-T4-TV / BECHLER A-AR-AS4 / GAUTHIER 1H-GM75-GM17 STROHM M45
042.060	10	14	57	36°	1 0x1	4,5	TORNOS M4
042.070	11	14,5	53	16°	10x0,75	7	TORNOS M7 / TSUGAMI NP-4W
042.080	12	15,5	50	16°	10x0,75	7	PETERMAN P7
042.090	12	15	52	30°	12x1	7	TORNOS M7-TV-MS1 / BECHLER A-AR-AS7 / PETERMAN NO1 R-P7-M7 STROHM M-SJ75K M75 / TSUGAMI NP-4W TORNOS-BECHLER ENC 16-162-164
042.100	13	16	41,5	15°	12,5x0,75	9	BECHLER AE7 - AE10 - AR10
042.110	13	17	68	5°	13x1	9	TORNOS M7 MAGIC
042.120	14	18	64	16°	13x0,75	9	TORNOS R10
042.130	16	19,8	58	16°	14x1	10	TORNOS MV-R10 / PETERMAN P7R / BECHET RMA7-RMA17 STAR SCN10DX-JNC10-RNC10 / CITIZEN G10-D10-L10-L101 -F12 NOMURA I-CAMNN 1053A / TORNOS-BECHLER ENC 16-162-164
042.140	16	20	55	30°	16x1	10	GIGY GL16 / PETERMAN P7R / TORNOS MV
042.150	18	24	69	36°	18x1	10	TORNOS MS7-R10 MAGIC
042.160	18	22	60	30°	18x1	12,7	TORNOS M10-R10-R125-MS7 / GIGY GL16

VODÍCÍ POUZDRA S VLOŽKOU SK SEŘIZOVATELNÁ

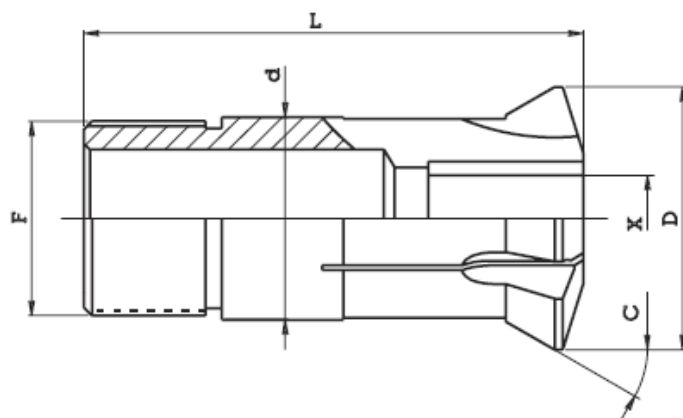

KOD	d	D	L	C	F	X max.	STROJE
042.170	18	22	60	30°	16x1	12,7	TORNOS M10-R10-R125-MS7 / BECHLER A-AR-AS 10 / MANURHIN TRAMINER 13 STROHM M-SJ 125K-M 105-125 / CITIZEN D10-L10-L101-F12 TSUGAMI NT-NP 11 / TORNOS-BECHLER ENC 16-162-164
042.180	20	25	55	30°	20x1	13	BECHLER A-AR-AS 10 / PETERMAN 10-10HS-PS127 / GAUTHIER 1H-GM75-GM1 27 STROHM 75-105-125 / TORNOS-BECHLER ENC 16-162-164
042.200	21	24	57,4	12,5°	18x1	12	STAR VNC1 2-SNC1 5DX-JNC1 6-RNC1 6
042.210	22	29	68	16°	19x1	12	TORNOS M14-M15-R1 6-M17 / PETERMAN 10R-10HSR / STAR VNC 12 MANURHIN TRAMITER 16-20 KMX 20-26-220-226-413 / STROHM 205-255 TSUGAMI NT-NP16-NT-NP17-MARK1 1
042.212	22	29	68	16°	22x1		TRAUB TNL 16-16G / STROHM M-SJ 155K / NOMURA SN127-SN1 60-NN160C-D STAR SNC1 5DX-JNC1 6-RNC1 6-SST1 6-KIR1 6
042.220	24	30	61	30°	24x1	16	TORNOS M15-R1 6-M20-RR20 / TORNOS-BECHLER ENC 16-162-164 TOP100 PETERMAN P16 / CITIZEN E16-E16J-F16-G16-L16I-L16N-L16IV-L16VI-L16E TSUGAMI NT-NP16 NT-NP17 MARK11
042.230	25	30	71	30°	25x1	16	TORNOS M14-M15-R16-M20-RR20 / PETERMAN 10R-10HSR / GAUTHIER GM15 BECHET RMA 12-RMA I12-RMA 15-RMA I15
042.240	27	30	57	13°	24x1	16	BECHLER BE 16-20
042.245	28	34	81	16°	25x1	20	STAR KNC1 6-VNC20-KNC20 / CITIZEN L20E-L20VI / TRAUB TNL16
042.246	28	38	81	30°	25x1	20	MANURHIN TRAMINER 20-KMX20-26-220-226 / TSUGAMI S20-NT-NP20-MARK1 1
042.250	32	40	71	30°	32x1	21	TORNOS M20-RR20-M24-M25 / PETERMAN 2A-P1 6R-P20-2AR-P20R BECHET RMA19-RMA I 19 / GAUTHIER GM20 / CITIZEN D1 6-E20-F20 TSUGAMI NT-NP20
042.255	34	41	87,5	10°	34x1	25	MANURHIN KMX26-KMX226 / STAR SNC25DX-KJR25 / CITIZEN E25-F25 NOMURA NN20R-NN25R / TORNOS-BECHLER ENC 16-162-164
042.260	35	40	65	12°	34x1	26	BECHLER CR26
042.270	40	45	65	12°	38x1	26	BECHLER C26-32
042.280	40	48	71	30°	40x1	26	PETERMAN P25-P25R / BECHET RMA25-RMA I 25-RMA32-RMA I 32-TCN32 GAUTHIER GM20-GM25
042.290	40	48	65	30°	40x1	26	BECHLER B-BR12 B-BR16 B-BR20
042.300	40	48	72	30°	36x1	25	TORNOS-BECHLER ENC 262-264 TOP200 / GILDEMEISTER GAC 25L STROHM M205-255 SN25C
042.302	41	46	54	10°	38x1	32	TSUGAMI MORI BS 32
042.305	42	49	81	16°	40x1	32	STAR JNC25-KNC25-JNC32-KNC32-VNC32 / CITIZEN E32 TSUGAMI NT-NP32 NT-NP32 MARK1 1 / MIRABEL 321 MANURHIN
042.310	43	48	65	12°	42x1	32	BECHLER CR 35
042.320	44	53	87	20°	40x1	32	TORNOS MR32
042.330	48	58	73	20°	48x1,25	32	TORNOS M25-M28-R28-MR32 / PETERMAN P25R
042.340	48	56	81	30°	48x1,25	32	BECHLER C-CR26 C-CR32

KLEŠTINY ERC V SADÁCH I JEDNOTLIVĚ

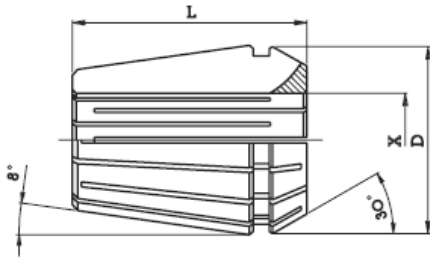

KLEŠTINY STANDARDNÍ

* SPECIALNÍ

KOD	Typ	D	L	X min.	X max.	Rozsah upnutí	Kusů v sadě
050.008	ERC 8	8,5	13,5	1	5	0,5	9
050.011	ERC 11	11,5	18	1	7	0,5	13
050.012	ERC 12	12	20	1	7	0,5	13
050.016	ERC 16	17	27	1	3	0,5	5
050.016	ERC 16	17	27	4	10	1,0	7
050.016*	ERC 16	17	22	11	12	1,0	2
050.020	ERC 20	21	31	1	3	0,5	5
050.020	ERC 20	21	31	4	13	1,0	10
050.020*	ERC 20	21	24	14	15	1,0	2
050.025	ERC 25	26	35	1	3	0,5	5
050.025	ERC 25	26	35	4	16	1,0	13
050.025*	ERC 25	26	26	17	20	1,0	4
050.032	ERC 32	33	40	2,5	3	0,5	2
050.032	ERC 32	33	40	4	20	1,0	17
050.032*	ERC 32	33	33	21	25	1,0	5
050.040	ERC 40	41	46	3	30	1,0	28
050.050	ERC 50	52	60	6	34	1,0	29

KLEŠTINY VYSOKÁ PŘESNOST

KOD	Typ	D	L	X min.	X max.	Rozsah upnutí	Kusů v sadě
050.008P	ERC 8	8,5	13,5	1	5	0,5	9
050.011P	ERC 11	11,5	18	1	7	0,5	13
050.012P	ERC 12	12	20	1	7	0,5	13
050.016P	ERC 16	17	27	1	3	0,5	5
050.016P	ERC 16	17	27	4	10	1	7
050.020P	ERC 20	21	31	1	3	0,5	5
050.020P	ERC 20	21	31	4	13	1	10
050.025P	ERC 25	26	35	1	3	0,5	5
050.025P	ERC 25	26	35	4	16	1	13
050.032P	ERC 32	33	40	2,5	3	0,5	2
050.032P	ERC 32	33	40	4	20	1	17
050.040P	ERC 40	41	46	3	26	1	28

MĚŘENÍ PŘESNOSTI

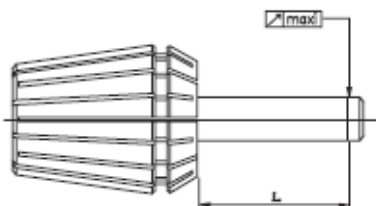

Otvor D			Maximální úchylnka (*)	
Min.	Max.	L	Kleštiny standard	Kleštiny vys. přesnost
1	1,6	6	0,015	0,010
1,6	3	10	0,015	0,010
3	7	16	0,015	0,010
7	10	25	0,015	0,010
10	18	40	0,020	0,015
18	26	50	0,020	0,015
26	40	60	0,020	0,015

KLEŠTINY ERC S UNAŠEČEM PRO ZÁVITNÍKY

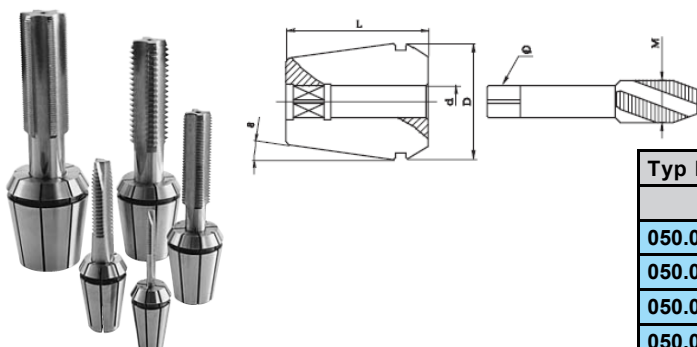

Typ ERC 16 D=21 L=31			
KOD	d	čtyřhran Q	M
050.016M D0350	3,5	2,7	M3
050.016M D0400	4	3	M3.5
050.016M D0450	4,5	3,4	M4
050.016M D0500	5	4	M4
050.016M D0550	5,5	4,3	M5
050.016M D0600	6	4,9	M5-6-8
050.016M D0630	6,3	5	M6-8
050.016M D0700	7	5,5	M10
050.016M D0800	8	6,2	M8

Typ ERC 20 D=21 L=31			
KOD	d	čtyřhran Q	M
050.020M D0350	3,5	2,7	M3
050.020M D0400	4	3	M3.5
050.020M D0450	4,5	3,4	M4
050.020M D0500	5	4	M4
050.020M D0550	5,5	4,3	M5
050.020M D0600	6	4,9	M5-6-8
050.020M D0630	6,3	5	M6-8
050.020M D0700	7	5,5	M10
050.020M D0800	8	6,2	M8
050.020M D0900	9	7	M12
050.020M D1000	10	8	M10

Typ ERC 25 D=21 L=31			
KOD	d	čtyřhran Q	M
050.025M D0350	3,5	2,7	M3
050.025M D0400	4	3	M3.5
050.025M D0450	4,5	3,4	M4
050.025M D0500	5	4	M4
050.025M D0550	5,5	4,3	M5
050.025M D0600	6	4,9	M5-6-8
050.025M D0630	6,3	5	M6-8
050.025M D0700	7	5,5	M10
050.025M D0800	8	6,2	M8
050.025M D0900	9	7	M12
050.025M D1000	10	8	M10
050.025M D1100	11	9	M14
050.025M D1120	11,2	9	M14
050.025M D1200	12	9	M16

Typ ERC 32 D=33 L=40			
KOD	d	čtyřhran Q	M
050.032M D0350	3,5	2,7	M3
050.032M D0400	4	3	M3,5
050.032M D0450	4,5	3,4	M4
050.032M D0500	5	4	M4
050.032M D0550	5,5	4,3	M5
050.032M D0600	6	4,9	M5-6-8
050.032M D0630	6,3	5	M6-8
050.032M D0700	7	5,5	M10
050.032M D0800	8	6,2	M8
050.032M D0900	9	7	M12
050.032M D1000	10	8	M10
050.032M D1100	11	9	M14
050.032M D1120	11,2	9	M14
050.032M D1200	12	9	M16
050.032M D1250	12,5	10	M16
050.032M D1400	14	11	M18
050.032M D1600	16	12	M20

Typ ERC 40 D=41 L=46			
KOD	d	čtyřhran Q	M
050.040M D0600	6	4,9	M5-6-8
050.040M D0700	7	5,5	M10
050.040M D0800	8	6,2	M8
050.040M D0900	9	7	M12
050.040M D1000	10	8	M10
050.040M D1100	11	9	M14
050.040M D1200	12	9	M16
050.040M D1400	14	11	M18
050.040M D1600	16	12	M20
050.040M D1800	18	14,5	M24
050.040M D2000	20	16	M27

Typ ERC 50 D=52 L=60			
KOD	d	čtyřhran Q	M
050.050M D0800	8	6,2	M8
050.050M D0900	9	7	M12
050.050M D1000	10	8	M10
050.050M D1100	11	9	M14
050.050M D1200	12	9	M16
050.050M D1400	14	11	M18
050.050M D1600	16	12	M20
050.050M D1800	18	14,5	M24
050.050M D2000	20	16	M27
050.050M D2200	22	18	M30
050.050M D2500	25	20	M33
050.050M D2800	28	22	M36
050.050M D3200	32	24	M39-42

KLEŠTINY CBA PRO VÝSTRUŽNÍKY A ZÁVITNÍKY (PLOVOUCÍ)

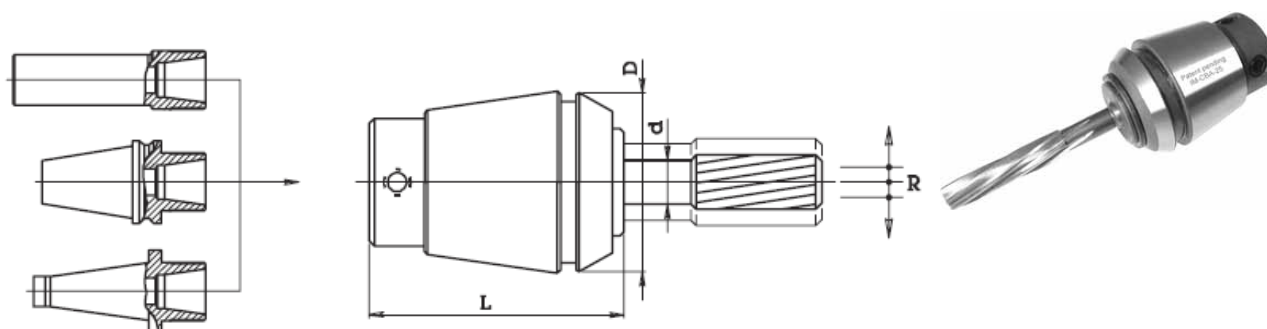

KOD	Typ	D	L	OTVOR d	R
IM-CBA-16	ERC 16	17	29	2 - 3 - 4 - 5 - 6 - 7	0.5
IM-CBA-20	ERC 20	21	32	3 - 4 - 5 - 6 - 7 - 8	0.5
IM-CBA-25	ERC 25	26	35	3 - 4 - 5 - 6 - 7 - 8 - 9 - 10	0.5
IM-CBA-32	ERC 32	33	44	4 - 5 - 6 - 7 - 8 - 9 - 10 - 11 - 12 - 13 - 14	0.5
IM-CBA-40	ERC 40	41	56	5 - 6 - 7 - 8 - 9 - 10 - 11 - 12 - 13 - 14 - 15 - 16	0.5

ODPRUŽENÉ KLEŠTINY

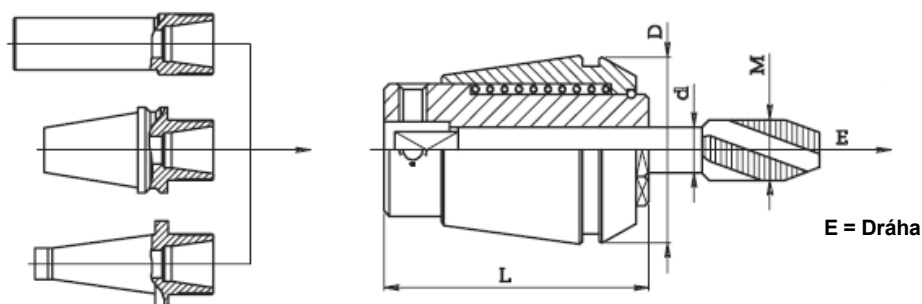

KOD	Typ	D	L	Rozměr závitníku M	Díra d	E
050.016 ZM	ERC 16	17	27	M1-M6	1,4 - 1,6 - 1,8 - 2 - 2,2 - 2,5 - 2,8 - 3 - 3,15 - 3,5 - 3,55 - 4 - 4,5 - 5 - 5,5 - 6	7
050.020 ZM	ERC 20	21	31	M1-M8	2,2 - 2,5 - 2,8 - 3 - 3,15 - 3,5 - 3,55 - 4 - 4,5 - 5 - 5,5 - 5,6 - 6 - 6,2 - 7 - 8	7
050.025 ZM	ERC 25	26	34	M3.5-M10 (M12)	2,5 - 2,8 - 3 - 3,15 - 3,5 - 3,55 - 4 - 4,5 - 5 - 5,5 - 5,6 - 6 - 6,2 - 6,3 - 7 - 8 - 8,5 - 9 - 10	8
050.032 ZM	ERC 32	33	43	M4-M12 (M16)	4,5 - 5 - 5,5 - 5,6 - 6 - 6,2 - 6,3 - 7 - 8 - 8,5 - 9 - 10 - 10,5 - 11 - 11,2 - 12 - 12,5	10
050.040 ZM	ERC 40	41	54	M6-M16 (M20)	6 - 6,2 - 6,3 - 7 - 8 - 8,5 - 9 - 10 - 10,5 - 11 - 11,2 - 12 - 12,5 - 14 - 15 - 16	13

KLEŠTINY ERC UTĚSNĚNÉ PRO VNITŘNÍ CHLAZENÍ

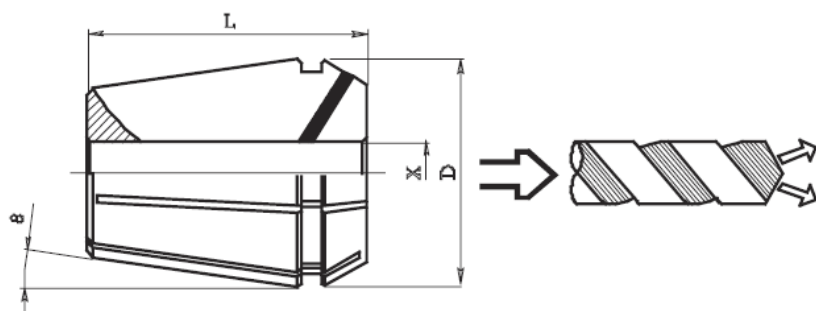

KOD	Typ	D	L	X min.	X max.	Rozsah upnutí	Kusů v sadě
050.011R	ERC 11	11,5	18	3	7	0,5	9
050.016R	ERC 16	17	27	3	10	0,5	15
050.020R	ERC 20	21	31	3	13	0,5	21
050.025R	ERC 25	26	35	3,5	16	0,5	27
050.032R	ERC 32	33	40	4	20	0,5	35
050.040R	ERC 40	41	46	4	26	0,5	45

MATICE ERC UTĚSNĚNÉ PRO VNITŘNÍ CHLAZENÍ

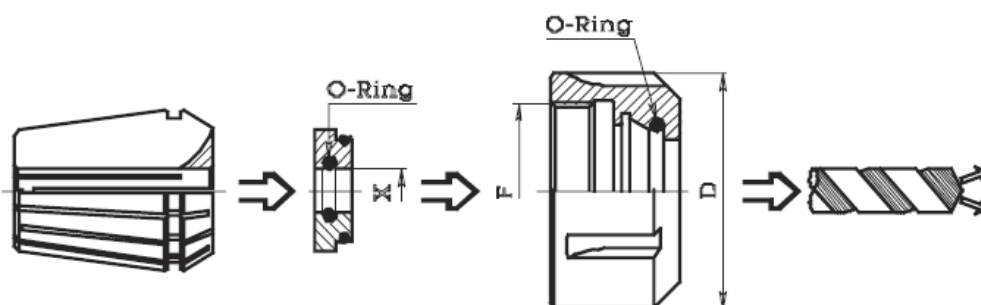

KOD Matice	Typ	D	F	KOD Klíče	KOD kroužku	X min.	X max.	Rozsah upnutí
052.216R	ERC 16	28	22x1,5	053.216	052.216RD	4	10	0,5
052.220R	ERC 20	34	25x1,5	053.220	052.220RD	4	13	0,5
052.325R	ERC 25	42	32x1,5	053.325	052.325RD	3,5	16	0,5
052.332R	ERC 32	50	40x1,5	053.332	052.332RD	3,5	20	0,5
052.340R	ERC 40	63	50x1,5	053.340	052.340RD	4	26	0,5

UKLÁDACÍ DESKA PRO KLEŠTINY ER

KOD	Kleština	poč. otv.
050.108 B	ERC 8	10
050.111 B	ERC 11	14
050.112 B	ERC 12	14
050.116 B	ERC 16	15
050.120 B	ERC 20	15
050.125 B	ERC 25	20
050.132 B	ERC 32	20
050.140 B	ERC 40	30

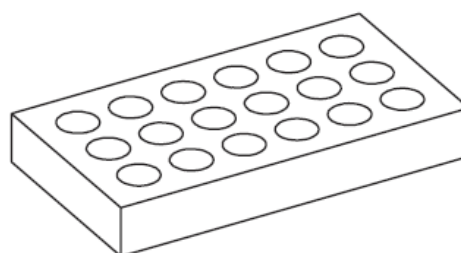

MATICE PRO KLEŠTINY ERC

MATICE MINI

Poz. 1

KOD	Typ	D	H	F
052.108	ERC 8	12	11	10x0,75
052.111	ERC 11	16	11	13x0,75
052.116	ERC 16	22	17	19x1
052.120	ERC 20	28	19	24x1
052.125	ERC 25	35	20	30x1

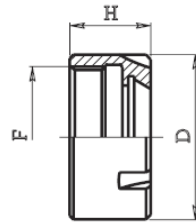

Poz. 1



MATICE ŠESTIHRAN

Poz. 2

KOD	Typ	D	H	F
052.211	ERC 11	19	11	14x0,75
052.216	ERC 16	28	17	22x1,5
052.220	ERC 20	34	19	25x1,5

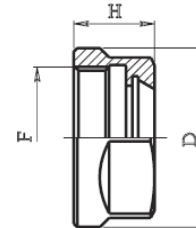

Poz. 2



MATICE STANDARD

Poz. 3

KOD	Typ	D	H	F
052.316	ERC 16	32	17,5	22x1,5
052.320	ERC 20	35	19	25x1,5
052.325	ERC 25	42	20	32x1,5
052.332	ERC 32	50	22	40x1,5
052.340	ERC 40	63	25	50x1,5
052.350	ERC 50	78	35	64x2

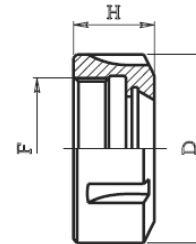

Poz. 3



MATICE VNĚJŠÍ ZÁVIT

Poz. 4

KOD	Typ	D	H	F
052.411	ERC 11	...	6	18x1
052.411 B*	ERC 11	...	6	18x1
052.416	ERC 16	...	8	24x1
052.420	ERC 20	...	11	28x1,5
052.425	ERC 25	...	12,5	32x1,5
052.432	ERC 32	...	14	40x1,5
052.432 B*	ERC 32	...	14	40x1,5

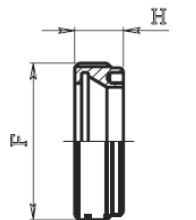

Poz. 4



KLÍČE PRO MATICE

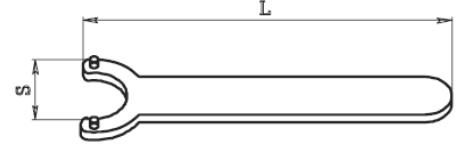
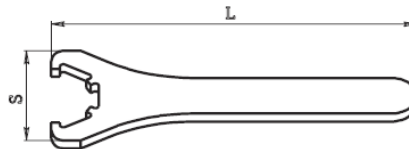
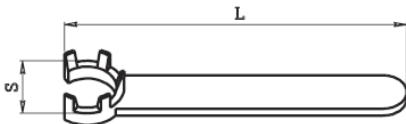

KOD	S	L	Pro kleštinu
053.108	12	80	052.108
053.111	16	96	052.111
053.116	22	118	052.116
053.120	28	130	052.120
053.125	35	132	052.125

KOD	S	L	Pro kleštinu
053.316	50	160	052.316
053.320	57	180	052.320
053.325	65	210	052.325
053.332	75	250	052.332
053.340	90	290	052.340
053.350	110	350	052.350

KOD	S	L	Pro kleštinu
053.420	20,5	160	052.420
053.425	23,5	180	052.425
053.432	32	200	052.432